



RCI-1502 LM Strut Boom System Instruction Manual

MAN-1072 Rev D



LSI-Robway Pty Limited, 32 West Thebarton Road, Thebarton, South Australia, 5031
Phone: +61 8 8238 3500 Fax: +61 8 8352 1684 www.lsirobway.com.au

Contents	Page No.
1. Important Safety Notice	3
2. General Description	4
3. Operating Instructions.....	5
3.1 Turning On the RCI-1502.....	5
3.2 Turning Off the RCI-1502	5
3.3 Operating Screen.....	6
3.4 Display Functions.....	7
3.5 Data Logging and Data Downloading	9
4. Installation	10
5. Calibration.....	16
5.1 Verifying Operation of Sensors.....	18
5.2 Configuring User Variables	19
5.3 Calibrating Boom Angle.....	24
5.3.1 Calibrating Low Boom Angle	24
5.3.2 Calibrating High Boom Angle	24
5.4 Calibrating Low End & High End of Transducer/s.....	25
5.4.1 Calibrating the Transducers to Force	25
5.4.2 Calibrating the Low End of Transducer 1	26
5.4.3 Calibrating the High End of Transducer 1	26
5.5 Calibrating Load for Active Winch	27
5.5.1 Calibrating Active Winch.....	27
5.6 Copying & Restoring Calibration Data Function	28
6. Troubleshooting.....	34
7. Electrical Specifications	40
8. Appendices	42

1. Important Safety Notice

The RCI-1502 System is a crane device which warns the operator of impending overload conditions and of overhoist conditions which could cause damage to property, crane and personnel.

The system is not a substitute for good operator judgement, experience and safe crane operation. The operator is solely responsible for the safe operation of the crane.

The operator must, prior to operation of the crane, read this manual carefully and thoroughly and shall ensure that all operational instructions and warnings are understood and complied with.

Proper system operation requires the operator to correctly program the RCI System to match the crane setup and working configuration.

The system is equipped with an override key which bypasses alarms and motion cut function at which time the system can no longer warn of impending overload and must only be operated strictly in accordance to the crane manufacturer's setup and operation procedures. Operation of this key is for authorised personnel only who shall be solely responsible for its use.

2. General Description

This Manual contains general information, installation, operation, calibration, maintenance and parts information for the RCI-1502 Rated Capacity Indicator to suit various Strut (Lattice) boom mobile cranes.

Refer to drawing DWG 2465 "RCI-1502 GENERAL ARRANGEMENT FOR TYPICAL STRUT BOOM LOAD MOMENT SYSTEM" on Section 8.2. of the Manual for an overview of the System.

Drawing (DWG) Numbers, where applicable in the following Sections, are also provided for quick reference.

The RCI-1502 is a fully automatic Rated Capacity Indicator which provides a display of the following functions:

- Boom Length,
- Boom Angle,
- Hook Radius,
- S.W.L. (Safe Working Load),
- Hoist Rope Falls,
- Duty (Configuration),
- Actual Load of Selected Winch (Main or Aux),
- Percentage of SWL (3 coloured lamps - green, amber, and red).

The RCI-1502 display also provides the following features:

- Visual and audible alarms on warning (approach to overload), overload, motion-cut, two-blocking detection, and error detection,
- Self-diagnosis and error codes,
- Data-logging,
- Built-in calibration and fault-finding tools,
- Units conversion (imperial/metric) facility,
- Anti-two-block (overhoist limit) facility.

3. Operating Instructions

The following sections explain how to operate the RCI-1502 and make best use of its capabilities.

3.1. *Turning On the RCI-1502*

Power to the unit is from the crane battery (nominal 12 or 24 volts dc) through the start-up or ignition key. In some applications an additional switch may be used to enable the operator to switch the unit on/off as required.

As soon as power is applied to the unit, its display and other indicators should light up and the unit should go through its self-test operation.

3.2. *Turning OFF the RCI-1502*

The unit will stop working as soon as the power is removed from it by switching off any of the switches indicated in Section 3.1 above.

3.3. Operating Screen

The following is the operating screen of the RCI-1502 showing the general display functions:

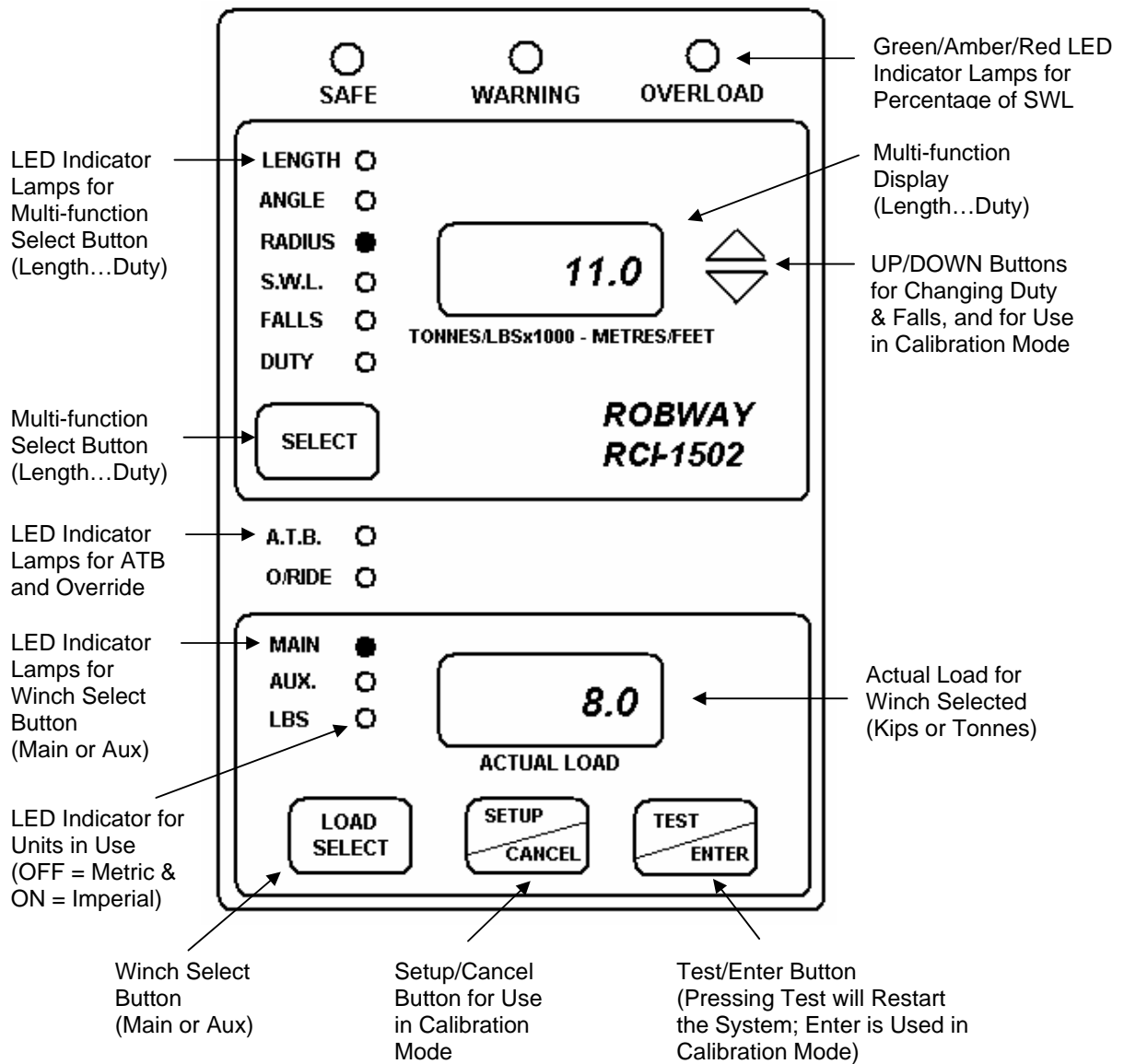

3.4. Display Functions

The RCI-1502 has 2 LCD display windows and 6 front panel push buttons. The display panel can also be grouped into four parts as follows:

3.4.1. “Approach to Rated Capacity” Indication Lamps

This is the uppermost part of the display which contains three coloured lamps to indicate “approach to rated capacity”. Factory settings are as follows:

- Green: 50 to 84%, Amber: 85 to 99%, Red: 100 to 110%
- Amber lamp flashes when first trip point is reached (i.e. 85% Rated Capacity) plus an intermittent audible alarm.
- Red lamp will flash at 100% of rated capacity plus a continuous audible alarm.
- Red lamp will stop flashing and will stay ON when the lifted load exceeds 110% of SWL plus a continuous audible alarm. Crane motion controls are also activated at this stage if fitted.

3.4.2. Numerical LCD for Various Functions

This is a numerical LCD display, just below the indication lamps mentioned above, which shows the LENGTH, ANGLE, RADIUS, S.W.L., FALLS, and DUTY status.

This window is also used to display ERROR codes when any errors are detected. The error function cannot be manually selected but will be displayed automatically if there are any errors. Please refer to Section 6. “Troubleshooting” for the meaning and description of the error codes.

The above functions are selected by pressing the SELECT button on the front panel. The selected function is indicated by the lamp next to the labels. The display functions are as follows:

LENGTH

The numerical display shows the BOOM length, in unit selected (feet or metres), for the winch selected.

ANGLE

The numerical display shows the current working angle in degrees which is read from the main boom angle sensor.

RADIUS

The numerical display shows the current working radius, in unit selected (feet or metres), for the winch selected.

SWL

The numerical display shows the current maximum safe working load in unit selected (kilopounds or tonnes). The S.W.L. will depend on the current crane configuration (duty), winch selected (if twin winch), the maximum linepull and the falls selected.

FALLS

The numerical display shows the number of falls (*parts of line*) used for the winch selected. To change the falls, press the UP/DOWN arrow keys to ramp to the desired falls number while the FALLS indicator is on, make sure the correct winch is selected.

DUTY

The numerical display shows the current duty (or configuration) number selected. Each system manual is supplied with a DUTY LISTING for a given application. Please refer to Section 8.4. "RCI System Configuration Sheet / Duty Listing at the rear of the manual for a description of the duties. A plastic encapsulated version is also supplied with the system for the crane operator's quick reference in the cabin.

To change the Duty number, use the UP/DOWN key to ramp to the desired value, while the DUTY LED indicator is on.

3.4.3. A.T.B. (Anti-Two-Block) and O/RIDE (Override) Indication LEDs

This part of the display has two red LED's which shows the current status of the following functions:

- O/RIDE - LED ON when over-ride/bypass key is switched on.
- A.T.B. - LED ON when on two-blocking condition.

The RCI-1502 is supplied with a standard Anti-Two-Block (ATB) input for connecting an optional ATB sensor to prevent two-blocking. When the ATB indicator on the front panel is lit, a two-blocking condition has occurred and further hoisting is stopped by activating the motion cut relay, if installed.

3.4.4. Numerical LCD for Current Load Readout

This part has a numerical LCD which shows the current load, in unit selected (kilopounds or metric tonnes), on the winch selected.

There are three red LED's on the left side of this window. The MAIN and AUX LED's indicate which winch is selected. The LBS LED indicates the units selected. LED ON means Imperial Units (kips, feet) and LED OFF means Metric Units (tonnes, metres).

Use the WINCH SELECT button to switch between MAIN and AUX winches. For Single Winch cranes, only the MAIN winch is active and the AUX LED is disabled.

Although the RCI-1502 will always check safe operation for both winches, you should make sure that the correct winch is selected as the winch selection affects the values shown on the displays.

When the ACTUAL LOAD exceeds the SWL for the current crane configuration the RCI-1502 will activate audible and visual alarms.

If the overload is higher than the SWL % for MOTION CUT OUTPUT, set in calibration mode, the instrument will also activate the motion cut relay, if installed. This will then stop further over-loading of the crane. To bypass or temporarily disable motion cut, the operator must use the over-ride key which should be held by the site-supervisor. When the key is inserted into the display and is turned on the O/RIDE indicator is illuminated as a reminder.

ROBWAY recommends that the over-ride key be switched OFF at all times and the over-ride key be held by the site-supervisor.

3.5 Data Logging and Data Downloading

For downloading data to PC, connect the Data-Logging Download Cable (Part No. CABCOM 1261) between the RS-232 socket at the back of the RCI-1502 display and the PC.

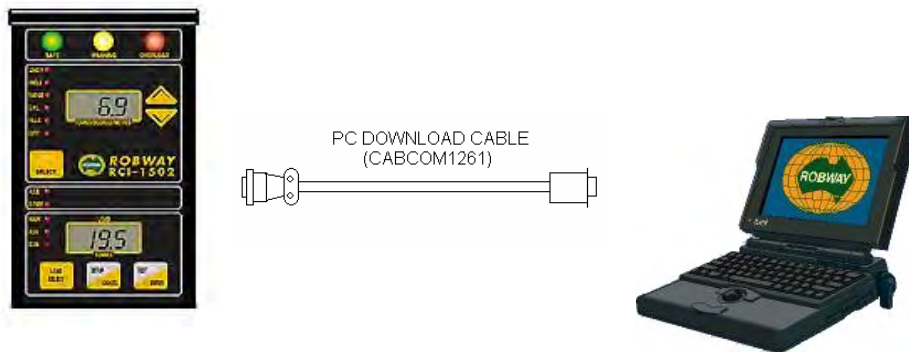

Please refer to Section 8.1. “DATA LOGGING ON RCI SYSTEMS” at the rear of the manual for usage information and details.

4. Installation

SETTING UP THE CRANE

Lower the crane boom to a safe and convenient position.

INSTALLING BOOM PARTS

Boom Angle Sensor

Fix the angle sensor orientated for right hand side (RHS) of the boom in a convenient position close to the operator's cab by bolting/welding the mounting bracket provided in a vertical plane at 90 degrees to the boom centreline.

It is usual to fit the angle sensor to the 'inside' of the LHS boom butt section. This position usually provides good mechanical protection. Ensure the arrow on the enclosure is pointing to the boom tip.

Mount/bolt the sensor on the mounting bracket and route the cable carefully around the boom pivot to the cab. Clip the cable to the boom and turret using adequate straps/cable ties provided ensuring that cable is not pinched or stretched as boom moves through its full luffing arc (see also "Cabling – Boom Sensors" item in this Section). Only connect the plug when finished welding.

Drawing Reference:

DWG 1099 – "Electronic Angle Sensor, Dimensional Drawing"

Please note that high tensile booms require proper welding procedure specifications. Obtain specialist assistance in these cases.



Electronic angle sensor and typical installation at the boom butt section

Load Sensor

The lifted load is calculated from monitoring the total forward moment force of the boom and deducting the luffing effects of the boom (and fittings) dead-weight.

Load-cells can be provided to monitor this force in a variety of ways. Most common method involves fitting Tension Plate type load-cells or Load Pins into the crane luff rigging at various locations, i.e. between the pendants and the boom, the dead-end of the luff rope reeving, back hitch pins of the A-frame, the equalising sheave of the luffing bridle and other locations.

Where a Tension Plate type load-cell is used, some special fitting, e.g. adapter plate assembly, to fix the tension cell at the dead-end of the luff rope may be required. This adapter plate assembly must be specially-fabricated and supplied by the customer to suit the dimensions of the lug and socket at the dead-end termination point. It should be fabricated from high-tensile grade material such as “Bisalloy 80” for plates and “grade 4140” for pins, and should provide for the existing wedge socket and pin to be re-used. Robway also recommends that the adapter plate assembly be proof-load tested by a certification body prior to installing it on the crane.

Alternatively, Robway can supply the adapter plate assembly (proof-load tested and certified) at extra cost at the time of ordering the RCI-1502 system. Dimensional details of the lug, wedge socket and pin will also be required by Robway at the time of ordering.

Drawing References:

DWG 0990 – “Tension Plate Cell Dimensions”

DWG xxxx – *Load pins are custom-made to suit application. If load pin is supplied, dimensional details and specification will be included in Section 8.2. “Drawings” at the back of the manual.

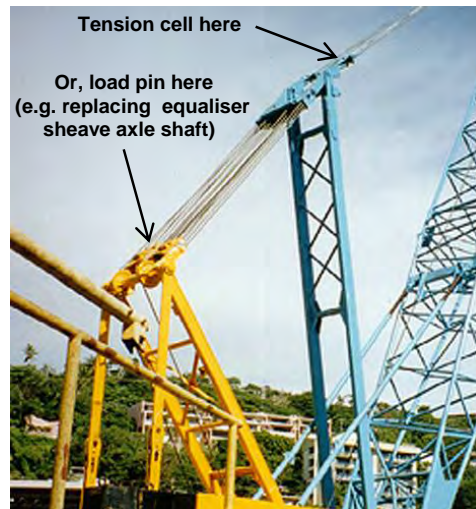
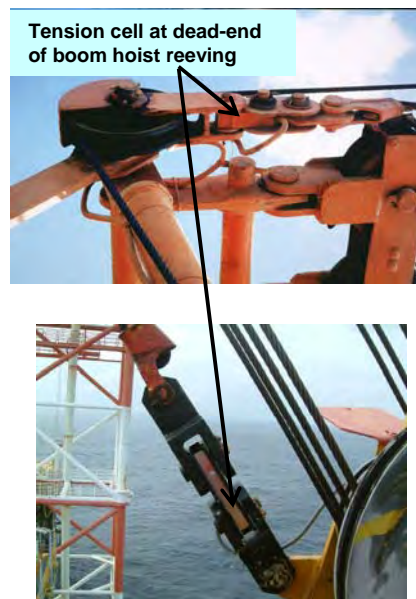

Typical installation of tension cell or load pin at the boom hoist section

Anti-Two-Block (Optional Item)

Fix the anti-two-block (ATB) switch mounting bolt by welding it to the boom head preferably so that the bob weight (when suspended from the switch) can be fitted to the static hoist rope below the rope anchor. Check that the switch works correctly as the boom luffs throughout its working range.

Additional switches (for fly-jibs) can be added. Connection is via the bullet-type connectors from the cable. When more than one ATB switch is required (e.g. main & fly), connect the ATB cables of the switches in series via the bullet-type connectors.

Hang the bob weight assembly from the switch eye after cutting the chain to length if desired to suit winch line speed. Repeat the procedure if required for rooster or fly jib.

Drawing References:

DWG 2934 – “Dimensional Detail, BB5 Anti-Two-Block Switch”

DWG 0667 (Sheet 3 of 3) – “ATB Switch Installation Details, Strut Boom”

Please note that high tensile booms require proper welding procedure specifications. Obtain specialist assistance in these cases.

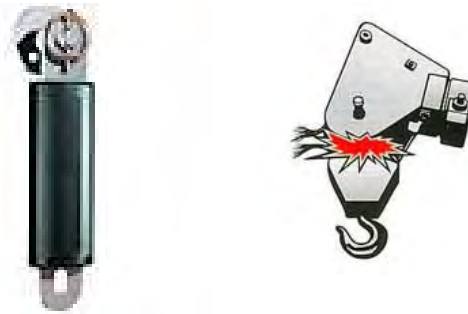

Model BB-5 anti-two-block (ATB) switch

Cabling (Boom Sensors)

Load, angle, and ATB cables should be fixed firmly to where they are installed and routed along the boom chords through to the crane cabin ensuring freedom of movement around the boom pivot pin.

The cables are normally quite robust. They should be treated with care, however, as even a small amount of damage can be very costly due to downtime or intermittent behaviour. Always support the cable in such a way that there is no "excessive" strain applied, such as tension or flexing. The cable should be strapped to a fixed member that it runs along, unless it is held within a cable tray or trunking. Clip cables at approximately 600mm intervals or where suitable to secure them firmly to the boom. Avoid sharp bends such as around a sharp corner. Where there is to be flexing, the installer must ensure that the bending is reduced to an absolute minimum to avoid fatigue breakage of the conductors.

Drawing Reference:

DWG 1244 – “RCI Series Cable Connections”

Connectors

It is recommended that the installer applies a suitable silicone grease (e.g., Dow Corning 4 “Electrical Insulating Compound” or any similar compound) on the plugs and sockets prior to connecting the cables. The silicone grease should be smeared across the connector contact points to increase the water proofing of the connector.

INSTALLING CABIN PARTS

Display Unit and Key Switch Box

Fit the RCI-1502 Display Unit and Key Switch Box in a convenient position in the crane cabin such that the operator can view the displays and reach the push buttons comfortably.

Connect the Switch Box power supply lead to the key start switch or directly to the battery via a relay that is energised by the key start switch. Ensure that the polarity of the power supply is correctly connected.

Standard back plate bracket and kit comprising of bolts and nuts are provided. Special bracket may need to be fabricated on site for suitable mounting in the cabin.

Connect the load, angle, and anti-two-block ATB cables to the display unit.

Note: If a good earth connection between the mounting bracket and the cabin cannot be guaranteed then the earthing wire attached to the base of the display must be used to properly earth the display. Failure to do so could result in a non-operational ATB signal and faults due to Radio Frequency Interference.

Drawing References:

DWG 0279 – “Dimensional Drawing, RCI-1502 Display”

DWG 2459 – “Dimensional Detail, RCI-1502 Switchbox”

DWG 3336 – “RCI-1502 Switchbox V2 Wiring Diagram”



Display unit and typical installation inside the cabin

WIRING SLEW SWITCH/ES AND MOTION CUT OUTPUT

Slew/Proximity Switch/es (Optional Items)

The slew switch is used when the crane has different zones of SWL (e.g. over-rear ratings, over-side ratings, etc.). The switch will convey a signal to the display when the crane moves into a zone of different capacity rating. The RCI-1502 system can interface with up to three switches maximum.

The switch is magnetically switched and requires a metal target to switch ON. Fabricate, fix and secure a suitable mounting plate to the switch between the two locknuts supplied. Mount the plate/switch assembly at a suitable location on the revolving upperstructure preferably so that the switch moves and rotates with the upperstructure. The metal target plate must be mounted at a safe and suitable location on the carrier about which the upperstructure rotates.

Alternatively, fix the switch and target plate around the centre post of the crane slew (refer to typical installation photo below).

The gap between the switch and target must not exceed 10mm. The switch distance can be adjusted via the locknuts.

Connect the switch to the RCI-1502 Switchbox V2 as per DWG 3336 (refer to Section 8.2. "Drawings" for details).

Drawing References:

DWG 2461 – "Dimensional Details, Proximity Switch (SWIPROX02)"

DWG 2462 – "Dimensional Details, Proximity Switch (SWIPROX03)"

DWG 930050 – "RCI Slew Switch Mounting"



Typical installation of slew/proximity switch

Motion Cut Output

The standard RCI-1502 Switchbox has an in-built relay to output the motion-cut signal. This allows connection of the crane's lockout solenoids direct into the Switchbox.

The Switchbox is fitted with a standard 24VDC (contact rating of 10A) relay when supplied from the factory. A spare 12VDC (contact rating of 10A) relay is also supplied with the installation kit supplied with the system. This is to replace the 24VDC relay if the crane's nominal supply is 12VDC.

To wire the crane's lockout solenoids, open the RCI-1502 Switchbox and use the following relay connections to match the solenoids:

<u>Relay Terminal No.</u>	<u>Contact Output Description</u>
3	Normally Open
4	Common
5	Normally Closed

The lockout solenoids on cranes are normally energised when crane is in safe condition (no alarm) and are de-energised when a motion cut condition occurs.

Use contact terminals 4 (com) and 5 (NC) of the motion cut relay to wire the supply coil of the lockout solenoids. During motion cut activation, the motion cut relay is de-energised. This opens the relay contacts and also de-energises the lockout solenoids.

The Switchbox has a spare gland for motion cut cable entry. Please note that the motion cut cable is not supplied with the RCI-1502 System as a standard component.

Drawing Reference:

DWG 3336 – “RCI-1502 Switchbox V2 Wiring Diagram”

5. Calibration

WARNING

Calibration by untrained personnel may result in corruption of sensitive calibration data. Therefore, entry into calibration routines should only be performed by trained personnel.

Entering Calibration Mode and Selecting Calibration Functions:

- Make sure that the correct duty number (crane configuration) and falls (parts of line) are selected,
- Insert the over-ride key switch into the RCI-1502 Switchbox and turn it on, make sure that the O/RIDE indicator on the front panel is lit,
- Press and hold the SETUP button for about 2 seconds,
- The TOP window should show F-xx, where xx is the last calibration function performed or 00 if this is the first time you entered calibration mode,
- Once calibration mode is entered use the UP/DOWN keys to ramp through the calibration functions,
- When the correct function code is shown in the TOP window press the ENTER button to select that function,
- To exit calibration mode either select F-00 or press the CANCEL key until the F-xx code is cleared from the TOP window.

Tools/Items Required for Calibration:

- An accurate angle finder for calibrating boom angle sensor,
- An accurate tape meter of at least 100 ft. long for verifying radius,
- A Robway RCI simulator is recommended,
- A notepad to record results,
- Software configuration sheets and function codes list (please see Section 8.3. "Function Codes" provided at the back of this manual),
- Known test weights to verify accuracy of load calibration.

Map of Calibration (Suggested Order):

1. Set date and time (F-32 to F-34).
2. Verify that raw counts stay within 33-999 for full working range of all sensors (F-07, F-15, F-19). F-19 is only required when two load sensors are used.
3. Review all crane geometry against the supplied Crane Configuration settings for correctness (F-45 to F-60) – refer also to Section 8.4. “RCI System Crane Configuration Sheet / Duty Listing” at the rear of the manual for factory default settings.
4. Review all SWL % parameters against actual requirements (F-42 to F-44) and change if required – refer also to Section 8.4. “RCI System Crane Configuration Sheet / Duty Listing” at the rear of the manual for factory default settings.
5. Review the data logger recording points against actual requirements (F-61 to F-67) and change if required – refer also to Section 8.4. “RCI System Crane Configuration Sheet / Duty Listing” at the rear of the manual.
6. Check Metric/Imperial units switching and set to required unit of measure using function code (F-69) if Single Winch or (F-70) if Twin Winch crane.
7. Calibrate low & high boom angle sensor (F-09, F-10).
8. View and check accuracy of the calibrated angle value in degrees on function code (F-08).
9. Calibrate the low and high end of transducer 1 (F-17, F-18). If using two load sensors, calibrate also the low and high of transducer 2 (F-21, F-22).
10. Calibrate load for active winch (F-02).
11. View and check accuracy of the calibrated Main load value in tonnes or kips, whichever “unit” is selected on item #6 above, using function code (F-01).
12. Apply averaging of samples, if required, using function code (F-27). Default value is 0 and maximum setting is 25. Try different value settings to stabilise the load readout if necessary. Refer to Section 5.2.15. for details.
13. Set friction correction, if required to improve accuracy, using function code (F-39). Refer to Section 5.2.25. for details.
14. Set the rigging SWL, if required, using function code (F-68) if Single Winch or codes (F-68-Main & F69-Aux) if Twin Winch crane. Refer to Section 5.2.31. “Main Winch Rigging SWL” for details.
15. Repeat calibration of active winch (F-02) on all duties (crane configurations). Copy the K1 and K2 values (F-38, F-39) of all duties calibrated.
16. Once satisfied with the calibration results, manually record (pen & paper) the calibration data using function code (F-40) and all settings mentioned above. Refer to Section 5.6. “Copying & Restoring Calibration Data Function” for details and procedures. Copy also the K1 and K2 values on function codes (F-37, F-38).

5.1. Verifying Operation of Sensors

Before you start calibrating the RCI-1502, you must make sure that the sensors are working correctly and their signals are reaching the RCI-1502.

The RCI-1502 'sees' the crane and its surroundings through sensors. The signals from these sensors are represented as numbers inside the RCI-1502. The range of possible numbers is 0 to 1023 for each sensor.

The RCI-1502 allows the user to view both the UNCALIBRATED or the CALIBRATED signal from a given sensor (*refer also to Section 8.3. "Function Codes" at the rear of this manual*).

When viewing the UNCALIBRATED signal from a sensor, make sure the number displayed is less than 999 and is more than 32 as you work the sensor through its working range. This is the correct operating range. Also make sure that the numbers displayed in the window are changing in a nice, smooth manner. If you find that the number is too unstable (i.e. changes by more than 10), then you should check the connections to the RCI-1502 (refer to Section 6. "Troubleshooting").

If the signal is less than 32, suspect a short circuit somewhere on that input channel, e.g. the cable to the RCI-1502 has been crushed and has an internal short circuit in it. Moisture inside the plugs can look like short circuit too.

If the count displayed in the window is 1023, look for an open circuit on that input channel. e.g. disconnected lead.

If the sensors check out then you can continue on and start with the calibration procedure. If you find any problems, check the troubleshooting guide at the end of this manual or seek help from your nearest ROBWAY distributor.

Please note that while in view mode, that is using either "VIEW UNCALIBRATED ..." or "VIEW CALIBRATED ..." functions, the ENTER key works as a toggle switch to turn that channel ON or OFF. This function allows the user to temporarily turn a sensor off.

To turn a channel back on, you have to re-enter the same VIEW UNCALIBRATED... function and press the ENTER key again.

Remember that you must always end a view function by pressing the CANCEL key.

5.2. Configuring User Variables

ROBWAY stores the load-charts, crane geometry, default alarm and motion control settings, default data logging parameters, fine-tuning settings, and other useful user variables in the memory of the RCI-1502 at the time of manufacture. As this information may vary from crane to crane, even if they are of the same model, the RCI-1502 allows the installer to change these variables on site. These user variables include dimensions such as slew-offset, maximum falls for main/aux winches, maximum line-pulls, sheave diameters, etc.

The actual values of these variables are printed on a configuration sheet (see Section 8.4. "RCI System Crane Configuration Sheet / Duty Listing" at the rear of the manual). A copy of this sheet is also supplied separately with the system.

To verify or change the current value of any of these user variables follow the procedure below:

- Enter calibration mode,
- Select the correct function code from the listing (see Section 8.3. "Function Codes") then using the UP/DOWN keys ramp to that function code and press ENTER,
- If you want to change the value use the UP/DOWN key to select the new value then press the ENTER key,
- If you only want to verify the current value press the CANCEL key when finished viewing,
- Now you should be back at the F-xx prompt and can continue on with the next operation.

Please note that the value of these variables is very important as they affect the safe operation of the RCI-1502 indicator. Therefore the values of the user variables must be checked and corrected if necessary before proceeding with further calibration or operation.

5.2.1. Exit Calibration Mode (F-00)

Use this function to exit Calibration Mode. Alternatively, exiting calibration mode can also be done by pressing CANCEL button when on a function code other than F-00. Ensure that dashes (---) are shown on the bottom window before pressing CANCEL button to exit.

5.2.2. View Calibrated Main Load (F-01)

The calibrated Main Winch load can be verified on normal operating mode (operator's screen). This function is used to view the main calibrated load while still in calibration mode. This is useful when just verifying accuracy of the load readout and the calibration has not yet been finalised.

5.2.3. Calibrate Load for Active Winch (F-02)

Please see Section 5.5. "Calibrating Load for Active Winch" for details.

5.2.4. View Uncalibrated Angle Input (F-07)

Use this function to view the raw counts (or raw data) of the angle sensor. Please also Section 5.1. “Verifying Operation of Sensors” for details.

5.2.5. View Calibrated Angle Input (F-08)

The calibrated angle can be verified on normal operating mode (operator's screen). This function is used to view the calibrated angle (in degrees) while still in calibration mode. This is useful when just verifying accuracy of the angle readout and the calibration has not yet been finalised.

5.2.6. Calibrate Low Angle (F-09)

Please see Section 5.3.1. “Calibrating Low Boom Angle” for details.

5.2.7. Calibrate High Angle (F-10)

Please see Section 5.3.2. “Calibrating High Boom Angle” for details.

5.2.8. View Uncalibrated Transducer 1 Input (F-15)

Use this function to view the raw counts (or raw data) of force transducer 1. Please also Section 5.1. “Verifying Operation of Sensors” for details.

5.2.9. View Calibrated Transducer 1 Input (F-16)

Use this function to view the calibrated transducer input. Please also Section 5.4. “Calibrating Low End & High End of Transducer” for details.

5.2.10. Calibrate Low End of Transducer 1 (F-17)

Please see Section 5.4.2. “Calibrating the Low End of Transducer” for details.

5.2.11. Calibrate High End of Transducer 1 (F-18)

Please see Section 5.4.3. “Calibrating the High End of Transducer” for details.

5.2.12. View Uncalibrated Transducer 2 Input (F-19) – If Using Two Force Transducers

Use this function to view the raw counts (or raw data) of the second transducer (transducer 2). Please also Section 5.1. “Verifying Operation of Sensors” for details.

5.2.13. Function Codes (F-20 to F-22) – If Using Two Load Transducers

These function codes are the same as function codes (F-16 to F18) but for the second transducer (transducer 2), if installed.

5.2.14. Function Codes (F-23 to F-26) – Not Used

These function codes are used for model RCI-4000IS System only.

5.2.15. Number of Sensor Samples to Average (F-27)

This function is used to stabilise the display in the event that the numbers (readouts during normal operating mode) are changing erratically. Function code F-27 will show the number of samples currently being used to average the sensor inputs. This value can be edited by using the Up/Down buttons. Default setting is “0” and the maximum selectable value is “25”. Try different settings until the readouts are stable.

5.2.16. Function Code (F-29) – Not Used

This function code is used for telescopic cranes only.

5.2.17. Load Chart View Mode (F-30)

This function code can be used to view the load charts programmed in the software. It is not part of the calibration or set-up procedures. It is mainly used by Robway for software checking.

5.2.18. View Luff Direction (F-31)

This function code is used to view the luff direction of the boom as follows:

2 – St	Boom Stationary
1 – UP	Boom Luffing Up
0 – dn	Boom Luffing Down

5.2.19. Set Year (F-32)

Use this function to set the current year.

5.2.20. Set Day and Month (F-33)

Use this function to set the current day and month.

5.2.21. Set Time (F-34)

Use this function to set the current time. The time displayed is in the format HH:MM. An invalid time will cause an error message to appear. The seconds can't be edited and will always be “00” (hidden). The seconds will begin incrementing once the OK button is pressed.

5.2.22. Download Logger Contents to PC (F-35)

Please see Section 8.1. “Data Logging on RCI Systems” at the rear of the manual for details.

5.2.23. Erase Logger Contents (F-36)

Please see Section 8.1. “Data Logging on RCI Systems” at the rear of the manual for details.

5.2.24. Set K1 and K2 Values (F-37, F-38)

K1 and K2 are load moment factors generated by the system after the calibration (F-02) of a selected Duty (crane configuration). These values are for Robway-trained personnel use only and should NOT be altered. Each duty will have its own K1 and K2 values generated after calibration. To copy the values for future reference and load moment data restoration, access the two function codes: F-37 for K1 and F-38 for K2. Press ENTER to display current value and copy the value with pen and paper. Press Cancel to exit function. To view and copy the values of other duties, first exit calibration mode and select the required duty. Access calibration mode again and use the same function codes to copy the values.

5.2.25. Set Friction Correction (F-39)

If inaccuracy of load reading is observed after the calibration, a correction factor measured as a percentage (%) of the load lifted can be applied to each selected Duty (crane configuration) and for each boom angle direction (e.g. luffing up or luffing down). Determining the best correction value is a trial and error procedure. Default setting is “0”. The friction correction value may differ from each duty and from each boom angle direction (Up or Down).

The system determines the boom angle direction through the parameters set on function codes **F-58 (Angle Sensor Range)** and **F-59 (Angle Sensing Time)**.

5.2.26. Alter Calibration Data (F-40)

This function is used for manually copying and restoring the calibration data which must be done after completing the system calibration. Please see Section 5.6. “Copying & Restoring Calibration Data Function” for details and procedures.

5.2.27. Clear All Calibration Data (F-41) – USE EXTREME CAUTION!

Activating this function will clear all the calibration data. This must only be used by Robway-trained personnel for troubleshooting purposes.

The display will prompt the operator to press ENTER if he wishes to erase the calibration data. Pressing ENTER here will clean out the memory system and default back to hard coded software. Any on-site changes made will be lost.

5.2.28. User Variables (SWL % Alarms, Motion Cut)

Function codes (**F-42 to F-44**) are used to set the Safe Working Load (SWL) percentages for activating Visual and Audible Alarms as well as the Motion Cut control output. The preset or factory default values are based on standard safe parameter settings and may be used. These values can be edited and changed using these functions codes to suit requirements.

5.2.29. User Variables (Crane Geometry & Falls Setting)

Function codes (**F-45 to F-57 & F-60**) are used to set the actual physical dimensions (geometry) and falls setting of the crane.

The factory default values are based on details and information received at the time of order and supply of system. Any changes to geometry will also require changing of these values using these function codes.

5.2.30. User Variables (Data Logging Setup Parameters)

Function codes (**F-61 to F-67**) are user variables relating to the setup parameters of the internal data logger. Please see also Section 8.1. "Data Logging on RCI Systems" at the rear of the manual for details.

5.2.31. Main Winch Rigging SWL (F-68)

This function is used to set a rigging SWL value for the crane and the Main boom to get past the maximum radius without activating the alarms. The value set must not exceed the weight of the empty Main hook block. When this function is used, the crane will assume a SWL equal to the weight of the hook block; thus, allowing the boom to go further down to the ground for rigging purposes without alarms as long as no load is lifted on the Main hook.

5.2.32. Auxiliary Winch Rigging SWL (F-69) – For Twin Winch Cranes Only

This function applies to Twin Winch cranes only and is the same function as the Main Winch Rigging SWL (refer to Section 5.2.31.) but for the Aux Winch.

Please refer to Section 8.3. "Function Codes" at the rear of this manual for the applicable set of codes. Two sets of codes have been provided in Section 8.3. One is for Single Winch cranes and the other is for Twin Winch cranes.

5.2.33. Metric/Imperial Units Switching: (F-69) – For Single Winch Cranes (F-70) – For Twin Winch Cranes

Use this function to select the required unit of measure (Metric or Imperial). Factory default setting is "Metric". Press the ENTER button while in this function code to toggle between Metric ("SI" shown on display) and Imperial ("Lbs" shown on display).

Please refer to Section 8.3. "Function Codes" at the rear of this manual for the applicable set of codes. Two sets of codes have been provided in Section 8.3. One is for Single Winch cranes and the other is for Twin Winch cranes.

5.3. Calibrating Boom Angle

5.3.1. Calibrating Low Boom Angle

- Safely luff the boom down to a low angle, e.g. 30°,
- Enter calibration mode, if not already activated, and select the correct function code (F-09) for calibrating low boom angle,
- Accurately measure the actual boom angle using an angle finder,
- Use the UP/DOWN keys to ramp the display to the required value then press ENTER to accept this value.

5.3.2. Calibrating High Boom Angle

- Safely luff the boom up to a high angle, e.g. 65°,
- Enter calibration mode, if not already activated, and select the correct function code (F-10) for calibrating high boom angle,
- Accurately measure the actual boom angle using an angle finder,
- Use the UP/DOWN keys to ramp the display to the required value then press ENTER to accept this value.

Verify that the boom angle is accurately measured by using function code (F-08) VIEW BOOM ANGLE. Luff the boom and stop on different boom angle points. Check boom angle with the Angle Finder and verify accuracy against the displayed angle.

5.4. Calibrating Low End & High End of Transducer/s

5.4.1. Calibrating the Transducers to Force



Note

The following procedure will be required if the force transducer is/has been changed from original supply and/or if a different (or customer-supplied) transducer is used.

Ensure that the force transducer/s is/are not yet installed on the crane (i.e. zero force) when doing this procedure.

Before going on to calibrating the load (active winch), the transducer/s must be checked and calibrated to force. This is done in the factory at the time of supply of original equipment and assuming the transducer/s is/are also supplied by Robway, in which case, there is no need to do this procedure on site.

If a different transducer is to be used, check its mV/V output (i.e. 1, 2, or 3mV/V). This output must match the amplifier gain setting of the RCI-1502 unit. The RCI-1502 is designed to work with 350-ohm load cells (transducers) with outputs of 1, 2, or 3mV/V. When supplied excluding the transducer/s, the amplifier gain of the unit is set to 3mV/V.

The installer can change this gain setting on site to match the transducer. This can be done by using a **Robway simulator** as follows:

- Switch off the display unit and connect the Robway simulator cable marked “MAIN LOAD” to the transducer 1 input cable of the display,
- Open the back cover of the display by removing the screws and carefully lifting the cover, ensuring that the wires between the cover and pcb are not pulled out,
- Locate the adjustable trimpot marked “MAIN” on the pcb (amplifier section),
- Switch on the unit and enter calibration mode. Select function code (F-15) to view the raw counts of the transducer,
- Set the “Main Load” pot of the simulator to position “5”. Using a trimpot adjuster or a small precision screwdriver, carefully turn the trimpot while viewing the raw counts on the display until the required raw count value is reached. The following are the required raw data values for each gain setting, with the load pot of the simulator switched to “5”:

1 mV/V - 980

2 mV/V - 490

3 mV/V - 327

- Once set, screw the back cover in place, ensuring that any wires coming out from the enclosure are firmly placed back in position inside the enclosure before tightening the screws.

5.4.2. Calibrating the Low End of Transducer 1



Note

The following procedure will be required if the force transducer is/has been changed from original supply and/or if a different (or customer-supplied) transducer is used.

Ensure that the force transducer/s is/are not yet installed on the crane (i.e. zero force) when doing this procedure.

- Connect the transducer to the display unit, ensuring no force is applied to the transducer,
- Enter calibration mode, if not already activated, and select function code (F-17) "Calibrate Low End of Transducer 1",
- Using the UP/DOWN keys, dial up "0.0" on the display. This is the zero value of the transducer,
- Press ENTER key to accept this value,
- Proceed to next step, "Calibrating the High End of Transducer 1".

5.4.3. Calibrating the High End of Transducer 1



Note

The following procedure will be required if the force transducer is/has been changed from original supply and/or if a different (or customer-supplied) transducer is used.

Ensure that the force transducer/s is/are not yet installed on the crane (i.e. zero force) when doing this procedure.

- Select function code (F-40) "Alter Calibration Data" and press the ENTER key,
- Using the UP/DOWN keys, select "tr1" on the display. Press the ENTER key and EDIT the following values:
 - Lo_r - Do not edit this value. This is the low raw counts value of the transducer.
 - Lo_c - Do not edit this value. This is the calibrated zero force value of the transducer.
 - Hi_r - Edit this item and enter "980" using the UP/DOWN keys.
 - Hi_c - Edit this item and enter the "full capacity value" of the transducer (e.g. "10" for a 10.0 tonne transducer).
- Refer to Section 5.6. "Procedures in Editing & Restoring Calibration Data" of this manual for further details and procedures on editing above items.

If using two force transducers, repeat above procedures 5.4.2. and 5.4.3. using function code F-21 (Calibrate Low End of Transducer 2) and editing item "tr2" on F-40 (Alter Calibration Data).

5.5. Calibrating Load for Active Winch

ROBWAY has introduced a new, simple method for calibrating load on Load Moment systems. This method does not require test loads for calibrating the load, instead it uses the un-laden boom which is calibrated at two different boom angles.

5.5.1. Calibrating Active Winch

- Make sure that the correct Duty, Falls, and Winch are selected for the actual crane setup before proceeding,

For this procedure, assume that the Main Winch has been selected first and being calibrated as follows:

- Luff the boom down safely to the lowest boom angle allowed by the load-chart. The lower the boom angle the more accurate the calibration will be. If the hook block is swinging or the boom is not stable, wait until they stop moving,
- Enter calibration mode, if not already activated, and select function code (F-02) "Calibrate Load for Active Winch",
- Enter the weight of the empty Main block (or "0.0" if the hook weight is part of the crane, refer to crane manufacturer's load chart) and then press ENTER,
- Once the bottom screen shows "HI", luff the boom up slowly to a high angle point just before the boom reaches the boom stops. Ensure that the boom stops are not reached as this will affect the accuracy of the calibration. Stabilise the boom for about 10 seconds and then press ENTER,
- Exit calibration mode and check the accuracy of the load display with a known weight, about 50% of the maximum SWL if possible. If adjustment is necessary to improve accuracy of the load readout, correction factors can be applied (see Section 5.2.21. "Set Friction Correction"),
- If crane has two winches (main & aux), exit calibration mode and then select Aux Winch on the Load Select button. Repeat above procedures using the same function code (F-02) and entering the Aux hook weight value (or "0.0" if the hook weight is part of the crane, refer to crane manufacturer's load chart).
- Repeat above procedures on all Duties (crane configurations) used. This requires physically setting up the crane to the duty to be calibrated.

5.6. Copying and Restoring Calibration Data Function

The latest software for the RCI-1502 System features a facility to easily VIEW, COPY, and RESTORE Calibration Data by using function code **F-40** “Alter Calibration Data”.

Procedures in Recording/Copying Calibration Data:

1. Access Calibration Mode.
2. Activate function code **F-40 (Alter Calibration Data)**.
3. Press ENTER button to select and access the Alter Calibration functions.

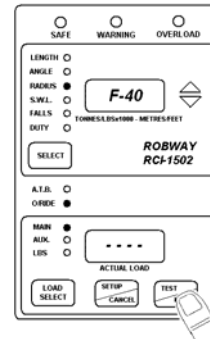

4. Function **An1 (Angle Channel)** will be displayed on top window. An1 is the default item that comes up whenever F-40 (Alter Calibration Data) is activated.
5. The calibrated value of Angle will be shown on bottom window (e.g., 80.5° as shown in this example).

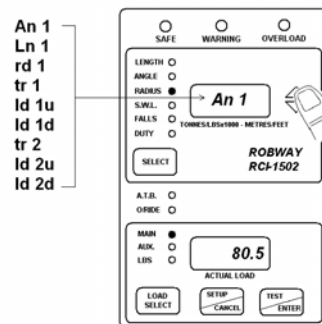

6. Use the Up/Down Arrow keys to go through all the following items listed below.

<u>Codes</u>	<u>Description</u>
*An1	Angle
Ln1	Boom Length
rd1	Radius
*tr1	Transducer 1
ld1u	Load 1 Up
ld1d	Load 1 Down
*tr2	Transducer 2
ld2u	Load 2 Up
ld2d	Load 2 Down

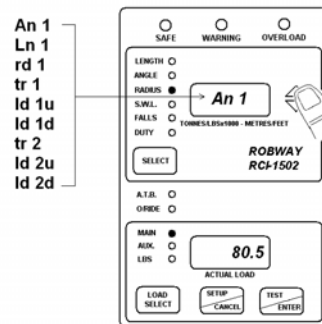

7. Only the “highlighted” items above must be copied (note: “tr2” must only be copied if using two transducers). To copy an item, select the item and press the ENTER key.

- In the example above, the default item **An1** has been selected.

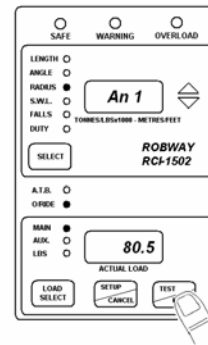

- Press ENTER key while on the selected item (e.g. An1) to activate the Edit Codes. There are four (4) Edit Codes as follows:

Edit Codes Description

Code	Description
Lo_r	Raw Counts of Calibrated Data (Low End)
Lo_c	Calibrated Data (Low End)
Hi_r	Raw Counts of Calibrated Data (High End)
Hi_c	Calibrated Data (High End)

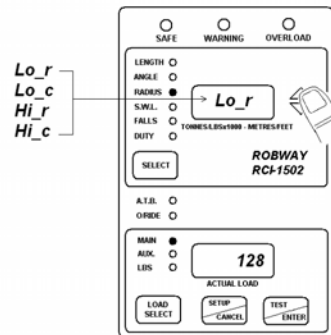

- The first Edit Code is **Lo_r** which refers to the **raw counts or raw data of the calibrated low angle** (e.g., 128 counts as shown in this example).

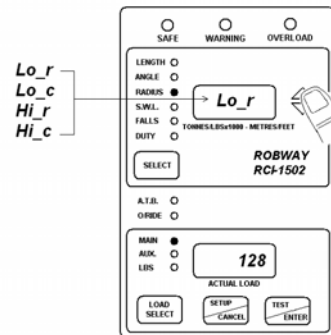

- Manually record/copy (with pen & paper) the **Lo_r** value.
- Use the Up/Down Arrow keys to go through and copy the rest of the edit codes (**Lo_c**, **Hi_r**, and **Hi_c**).

- Press CANCEL key to return to the item **An1** screen.

- Select the next item, **tr1**, and repeat above procedures 6 to 13. Select and repeat the same on **tr2** if two force transducers are used.

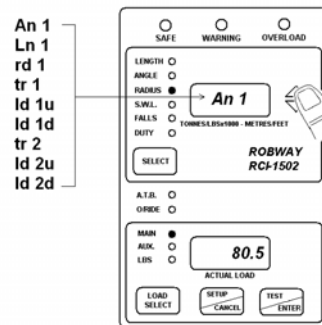

15. Ensure that the Edit Codes for the following items have been recorded/copied before exiting Calibration Mode:

An1
tr1
tr2 (if using two transducers)

16. Keep the record for future use (e.g. to re-calibrate the system when calibration data is lost due to faults, or when the Eprom software chip or Dallas memory chip has been replaced with a new one).
17. To fully restore calibration data, K1 and K2 load moment calibration values must also be copied. Refer to Section 5.2.24. "Set K1 & K2 Values" for details and procedures.

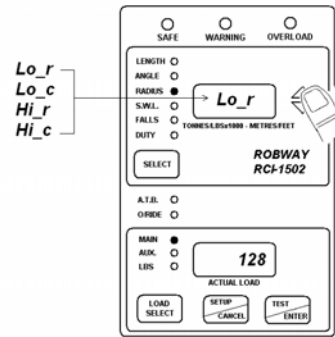

Procedures in Editing & Restoring Calibration Data:

1. Access Calibration Mode.
2. Activate function code **F-40 (Alter Calibration Data)**.
3. Press ENTER button to select and access the Alter Calibration functions.
4. Function **An1 (Angle Channel)** will be displayed on top window. **An1** is the default item that comes up whenever F-40 (Alter Calibration Data) is activated.
5. The calibrated value of Angle will be shown on bottom window (e.g., 80.5° as shown in this example).

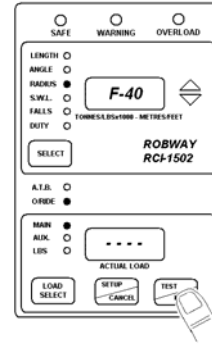

6. Use the Up/Down Arrow keys to go through all the following items listed below:

<u>Codes</u>	<u>Description</u>
An1	Angle
Ln1	Boom Length
rd1	Radius
tr1	Transducer 1
ld1u	Load 1 Up
ld1d	Load 1 Down
tr2	Transducer 2
ld2u	Load 2 Up
ld2d	Load 2 Down

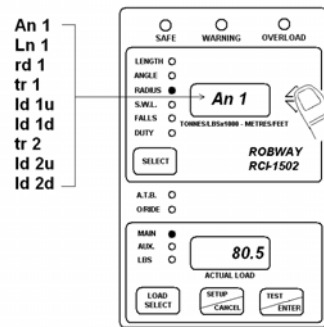
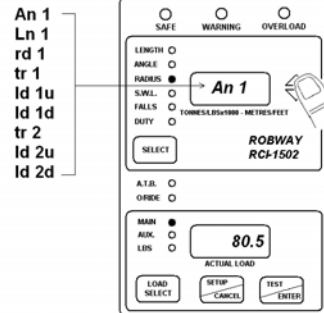

7. Only the “highlighted” items above must be restored (note: “tr2” must only be restored if using two transducers). To restore an item, select the item and press the ENTER key.
8. In the example shown, the default item **An1** has been selected. Press the ENTER key while on the selected item (e.g. An1) to activate the Edit Codes.

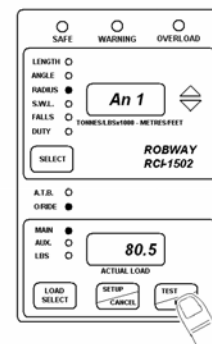

- Use the Up/Down Arrow keys to go through the list of the four (4) Edit Codes as follows:

Edit Codes Description

Edit Codes	Description
Lo_r	Raw Counts of Calibrated Data (Low End)
Lo_c	Calibrated Data (Low End)
Hi_r	Raw Counts of Calibrated Data (High End)
Hi_c	Calibrated Data (High End)

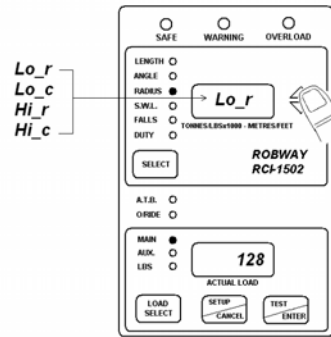

- The first Edit Code is **Lo_r** which refers to the **raw counts or raw data of the calibrated low angle** (e.g., 128 counts as shown in this example).

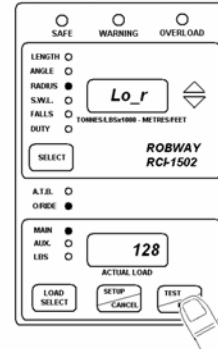

- Press the ENTER key to access edit mode (i.e. the word "EDIT" comes up on the top window).
- Use the Up/Down Arrow keys to change the **Lo_r** value with the previously copied data.

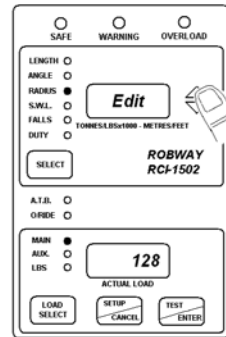

- Press the ENTER key to store this new value to **Lo_r** (e.g. from 128 to 109 as shown in this example).

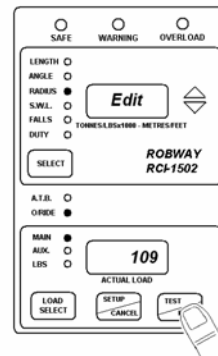

- The screen will then return to the **Lo_r** Edit Code screen.
- Select the next Edit Code and repeat procedures 9 to 15 until all Edit Codes have been edited (i.e. calibration data have been restored).

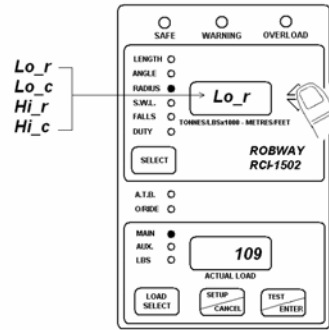

- Once all of the Edit Codes for **An1** have been edited, press the CANCEL key to return to the **An1** screen.
- Repeat procedures 6 to 16 until all of the items have been edited.
- Ensure that all of the following items have been edited before exiting Calibration Mode:

An1
tr1
tr2 (if using two transducers)

- To fully restore calibration data, K1 and K2 load moment calibration values must also be restored. Refer to Section 5.2.24. "Set K1 & K2 Values" for details and procedures.

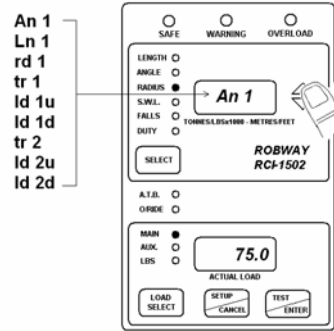

6. Troubleshooting

The RCI-1502 system incorporates a number of software features that are designed to help the service person quickly identify a fault, **however** it must be stressed that these features cannot identify everything. They can only be used as a guide to identify additional checks that can be made. Some notes are provided below, followed by some example faults and possible causes.

- 1. Identify the symptoms.** Take time to find out exactly what is happening to indicate a problem. If possible have the problem demonstrated so you can "describe it in your own words". Sometimes what someone else has told you is only part of the story.
- 2. Leave the calibration alone!** Too many times a re-calibration has been attempted in order to rectify a problem before that problem has been correctly identified. This leads to added confusion as the perspective is generally moved from the real fault to "calibration problems". We have often received a message indicating that our display has "not accepted the calibration data". Most times this is due to a fault in a cable or sensor which was not identified prior to re-calibration. Re-calibration must only be performed when all physical inputs have been verified for correct operation, and in actual fact is rarely ever needed.
- 3. Do you have your simulator with you?** A simulator is a very quick way to verify if the fault is external to the display and will save you a lot of heartache.
- 4. Have you read the manual?** When all else fails, read the manual! Your answer may actually be in there.
- 5. Know what information you need to gather.** If you collect the correct information from the display the job is half done. Before you begin to suspect faults with the system, you must satisfy yourself that the display is correctly configured for the crane environment. In other words, check that the correct duty, falls, slew zones etc. have been selected. Are all of the sensors connected? In general if sensors have been supplied with the system, they must always be connected. The display will check them continuously and issue an error if that sensor cannot be detected. Check your length, angle and radius against the chart to verify that the equipment is permitted to be in that situation. If there is still a problem once these have been checked, then you will need to check the hardware.
- 6. The main pieces of useful information** obtainable from the displays are the **raw counts**. The raw count shows what the actual inputs are doing (i.e. like a signal strength indication). These raw counts are manipulated in software according to the calibration data stored in the display to produce the readouts on the Display Unit. If the calibration has been done incorrectly, or the configuration is incorrect, or something else is wrong, then the Display Unit readouts (e.g. the LOAD or ANGLE values) may provide you with misleading information.

YOU MUST USE THE "VIEW UNCALIBRATED...." FUNCTION CODES TO DETERMINE THE CORRECT OPERATION OF THE EXTERNAL SENSORS, NOT THE "CALIBRATED" VALUES. It should be noted here that for load related problems, the **"VIEW UNCALIBRATED TRANSDUCER"** function code must be used, and not **"VIEW CALIBRATED LOAD"**. For correct operation these values must be in the range 32 to 999. Anything outside of this range will produce an error. Refer to Section 5. "Calibration" on how to access these raw counts.

- 7. Check the obvious.** Once you have found a problem with a sensor for example, check all of the obvious things to do with that sensor such as making sure all of the connectors are tight. Be systematic - make notes about what you have done and what you found. You will find that under pressure you can easily forget what you have checked and it becomes very easy to miss things.

EXAMPLE PROBLEMS AND POSSIBLE CAUSES

Problems That Produce Error Codes:

Error code 101.

This is indicating that the signal from the angle sensor is too low or too high. This should be confirmed by viewing the UNCALIBRATED ANGLE INPUT and noting that the value shown in the LOAD display is less than 33, or higher than 999.

Possible causes:

- Angle sensor incorrectly mounted. This is especially critical for the Electronic Angle Sensor. Refer to Section 6. "Installation" of the manual for installation of the angle sensor.
- The angle sensor signal wire is short circuited to the shield or to the angle 0V.
- The angle sensor signal wire is shorted to the excitation positive wire.
- The angle sensor is not connected or there is an open circuit in either the angle sensor signal wire or the angle excitation positive wire.
- The angle sensor excitation voltage is shorted. If this is the case it will also affect the length and load channels.
- The angle sensor 0V wire is open circuit.

Error code 201.

This is indicating that the signal from the force transducer 1 is too low or too high. This should be confirmed by viewing the UNCALIBRATED TRANSDUCER 1 INPUT and noting that the value shown in the LOAD display is lower than 33, or higher than 999.

Possible causes:

- Load cell signal wires shorted together.
- The signal + is shorted to the shield.
- The excitation - is shorted to the shield.
- The excitation supply is shorted together. This will obviously affect all of the external sensors. Measure the excitation voltage and compare it with the expected value. If this is the cause, the UNCALIBRATED value will generally be non-zero, but below 33.
- The load cell is disconnected or there is an open circuit in one of the signal wires.
- The signal - is connected to the shield.
- The signal + and the excitation + are swapped.
- The signal - and the excitation - are swapped.

Error code 202. - (If Using Two Force Transducers)

This is indicating that the signal from the force transducer 2 is too low or too high. This should be confirmed by viewing the UNCALIBRATED TRANSDUCER 2 INPUT and noting that the value shown in the LOAD display is lower than 33, or higher than 999.

Possible causes:

- Load cell signal wires shorted together.
- The signal + is shorted to the shield.
- The excitation - is shorted to the shield.
- The excitation supply is shorted together. This will obviously affect all of the external sensors. Measure the excitation voltage and compare it with the expected value. If this is the cause, the UNCALIBRATED value will generally be non-zero, but below 33.
- The load cell is disconnected or there is an open circuit in one of the signal wires.
- The signal - is connected to the shield.
- The signal + and the excitation + are swapped.
- The signal - and the excitation - are swapped.

Error code 240.

This is indicating that an overload has been detected. This error generally accompanies most other errors simply because most other errors will place the display into an overload condition. This being the case, you need to check what other errors are present and correct them first. Once these have been addressed the E240 error generally takes care of itself. The exception is of course, when the equipment has been put into a genuine overload situation which has not been caused by any external faults.

Possible causes:

- A genuine overload condition exists.
- There is a load on the auxiliary winch in a duty that does not allow anything on that winch.
- It has been caused by another Error code condition.

Error code 280.

This is indicating that the rated line pull has been exceeded.

Possible causes:

- A genuine line pull error exists.
- The number of falls selected is incorrect for the load being lifted, or does not match the actual falls reeved.

Error code 301.

This is indicating that the angle being measured is outside of its allowed range.

Possible causes:

- A genuine violation of the angle limits has occurred.
- The angle sensor mounting may have loosened allowing the sensor to move.
- Wrong duty selected.
- Check the angle displayed against the actual angle of the boom.

Error code 304.

This is indicating that the radius being measured is outside of its allowed range.

Possible causes:

- A genuine violation of the radius limits has occurred.
- Wrong duty selected.
- Check as per Error code 301.

Problems That Do Not Produce Error Codes:

The load does not vary when I lift a weight.

The load cable and/or the load sensor is/are faulty. Check the load cable for faults. If cable is good, check the resistance values of the load cell. This, however, does not give the complete story. Even if the resistances are correct, there is still a chance that a fault on the sensor exists. Contact your nearest Robway distributor/service agent for assistance.

When the system starts in the morning the displays are erratic, but settle during the day.

This is a common sign of moisture ingress into either the display, the connectors, the sensors or the cable. These should be checked, dried and sealed.

The display does not start.

You should check the power supply. The RCI-1502 has a voltage range of 10 – 40 vdc. If the supply is within range, open the Switchbox and check the fuses.

The unit is on alarm, but no error code on display.

- Check for Two blocking condition.
- If no Two Blocking condition exist but the ATB LED on display is ON, check the “earth lead” from the display for proper grounding to crane chassis.
- If “earth lead” is OK, check the ATB switch and cable for faults.

On start-up the display shows “LCtrl” on top screen and then hangs (boot up not completed).

- This is a data logger control error. It happens when the internal data logger has been corrupted; when an upgraded or new software has been installed; or when the memory chip (Dallas IC) has been replaced with a new one.
- To fix this error, insert and turn the override (bypass) key ON, then press the ENTER button. The display will show “YES” to confirm. While “YES” is shown on the screen, press the ENTER button again until the display gets into the normal initialisation/ set-up routine and then to normal operating mode.

7. Electrical Specifications

Power Supply Input (VDC)

Range: 10 VDC - 40 VDC

Power Consumption

< 1 amp (in full alarm)

Temperature Range

Operating: -20°C to +70°C

Digital Inputs

Total of three (3) digital inputs for connecting slew/proximity switches for monitoring different zones of operation, and/or for connecting other types of switches for any special crane requirement/application. Refer to Section 6.0 "Installation" of the manual for application details.

Motion Cut Relay Output

One (1) standard motion cut relay output available for wiring to crane lockout solenoids to inhibit crane motion when on overload/alarm condition. The relay fitted in the Switchbox is rated 10A @ 30 VDC. A spare 12 VDC relay is also supplied with the installation kit for use on 12 VDC cranes. Refer to Section 6.0 "Installation" of the manual for application details.

Sensors

Load Sensor/s

Capacity: Various capacities to suit application
Excitation Voltage: 4.0 VDC regulated (provided by the Display unit)
Linearity: 0.15% nominal
Repeatability: > 0.10%
Hysteresis: < 0.10%
Creep: < 0.10%
Output: 1, 2, or 3 mV/V nominal
Isolation: > 2000 MOhms at 50 VDC
Overload: 150% (no electrical damage)
> 400% (ultimate)

Temperature Effects:

On Zero: < 0.006% / °C

On Span: < 0.005% / °C

Compensated Range: -10°C to +70°C

Sealing: IP68 fully encapsulated

Pin/Wire Connections:

Pin A	Black	Negative Excitation
Pin B	White	Negative Signal
Pin C	Red	Positive Excitation
Pin D	Green	Positive Signal
Pin E	Screen	Screen

Expected Resistances (for a standard 350-Ω cell):

Red - Black 300 - 600 Ω

Red - Green 200 - 400 Ω

Red - White 200 - 400 Ω

Black - Green 200 - 400 Ω

Black - White 200 - 400 Ω

White - Green 350 Ω ± 2 Ω

Shield/Screen to any other wire must be open circuit

Electronic Angle Sensor

Excitation Voltage: 4.0 VDC regulated (provided by the Display unit)
Operating Range: +/- 45° (offset mounted to accommodate 0 - 90°)
Accuracy: +/- 0.2°
Cable Entry: 3-pin mil-spec type connector
Mounting: Via backplate bracket to boom base
Weight: 0.5 kg
Pin/Wire Connections:

Pin A	Red	Positive Excitation
Pin B	White	Signal
Pin C	Black	Negative Excitation

Expected Resistances:
High ohms or open circuit between any of the wires and chassis or shield

Proximity Switch

Type: PNP – N.O. & N.C.
Sensing Range: 10 mm
Operating Voltage: 10 – 30 VDC
Switching Current: 200 mA maximum

Anti-Two-Block Switch (Model BB5)

Type: V4 IP67 sealed, leaf
Contact Rating: 28 VDC/3A
Electrical Life: 10⁵ operations
Operating Force: 0.6 N (max)
Release Force: 0.08 N (min)

Cables

General: 2-, 4-, 6-, & 10-core braided, UV stabilised, PVC sheathed cables
DC Resistance: 38.2 ohms/km @ 20°C (25.45 ohms/km for 2-core cable)
Core Insulation: V90-HT PVC (designed to comply to AS/NZ 3808:2000)
Electrical Life: 10⁵ operations
Cable Integrity: All cores tested for insulation resistance @ test voltage of 500V
Sheath: Overall 5V90 UV stabilised PVC
Current Rating: 3 amps
Capacitance: 150 pf/m (core to core)

Appendix 8.1.

Data Logging on RCI Systems

Data Logging on RCI Systems

Introduction

The RCI System Logging occurs automatically whenever the driver lifts a load OR whenever the RCI System detects an error condition on the crane such as moving outside the load chart. The installer has the option to set the percentage of SWL a load must reach before the load will be logged. This *logging percentage* can be set anywhere between 13% and 110% of SWL.

In addition, the installer can configure three *lift counters* which can count the number of lifts performed in three distinct SWL % regions below the *logging percentage*.

Description of Logging Features

Data Logging is stored in a circular arrangement. That is, when the logs are full and another log is performed, the oldest log in the logger will be over-written. Each record stores the following data:

Date	Date log was recorded (dd/mm/yyyy)
Time	Time log was recorded (hh:mm)
Peak Load	Peak load recorded during log cycle
Stable Load	Maximum Stable load recorded during log cycle
Safe Working Load	SWL at operating position
Percent of SWL	Percentage of SWL
Radius	Operating Radius
Error Codes	4 digit <i>standard Robway Error Codes</i>
Duty Number	Selected Duty number
Winch selected	Selected winch
Falls reeved	Selected falls
Over-ride state	Off / On indicates whether display was in over-ride

Logging is performed automatically when the percentage of SWL exceeds a threshold value which is set in Function Codes.

When the *logging percentage* is not exceeded while lifting a particular load, the lift occurrence can still be recorded in a *lift counter*. Three separate *lift counters* can be configured to store the number of lifts which occur in a particular SWL % region. Once again, the exact SWL percentages which will be counted can be configured by setting the appropriate Function Codes.

Data Logging on RCI Systems

A summary of the logging percentage Function Codes is displayed in the following table:

Function Code Name	Description	Default Setting
Low Load Lift counter	swl percentage to record	20.0%
Medium Load Lift counter	swl percentage to record	40.0%
High Load Lift counter	swl percentage to record	65.0%
Logging Percentage	swl percentage to log	90.0%

These default settings would give rise to the following logging operation:

Low Load Lift Counter	counts the number of lifts which produce a SWL % which is greater than or equal to 20% but less than 40%.
Medium Load Lift Counter	counts the number of lifts which produce a SWL % which is greater than or equal to 40% but less than 65%.
High Load Lift Counter	counts the number of lifts which produce a SWL % which is greater than or equal to 65% but less than 90%.
Logger	Records full configuration data of any lift which produces a SWL % which is greater than or equal to 90%

Setting Up the Data Logger

Data logging will occur at all times the display is operational. This includes the cases when, the over-ride is activated, the display is reporting an error and during the initial calibration of the system.

For the Logger to operate properly the display must be fully and correctly calibrated. However, since the logger was recording during calibration it is probably desirable to erase the logger contents after completing the angle and load calibrations on the RCI System since the logger would have recorded some invalid information during the calibration of the sensors.

To erase the data logger contents, simply activate the appropriate Function Code once calibration is complete (refer to Function Codes list at the rear of the Manual for the appropriate code).

The operator can access three more Function Codes which control how the actual logging of loads operates. These three Function Codes are summarised in the following table

Stable Load Time	time during which load must stay stable in order to log
Stable Load Variation	load must stay within this variation to be considered stable
Reset Time	load must stay below the Low Load Counter threshold for this time before the log cycle ends

Data Logging on RCI Systems

The first two Function codes in the table are used for determination of a stable load. When a load is hoisted it is probable that the initial load reading will be greater than the actual load on the hook because of the "snatching effect". The stable load is recorded only when these dynamic factors have died down and the load can be considered to be hanging from the hook in a relatively motion free position.

The "Stable load time" and "Stable load variation" Function codes can be used to adjust the load recording to minimise the effect of dynamic factors. The load will be considered stable if the load reading does not change by more than the "Stable load variation" setting (which is 0.1t by default) for a period of time set by "Stable load time" (which is 2 seconds by default).

The third Function code, "Reset time," is used for terminating a lift. When the load causes a SWL % which is less than the logging values (specifically the Low Load Lift counter percentage), then it is assumed that the driver must be putting the load down again. In order to ensure that a single load is not logged multiple times because the SWL % was hovering around the logging threshold, a log cycle will not complete until the load SWL % remains below the threshold for a certain period of time, namely of course the "Reset time" (by default the reset time is set for 5 seconds).

Log Cycle Description

Two types of log cycles are possible:

1. Load is lifted inside load chart boundaries (valid SWL is seen at all times).
2. SWL drops to 0 indicating the load chart has been exceeded, sensor error has occurred or slew error has occurred.

Type 1 Log- Valid SWL cycle

A log cycle is started when:

- the current SWL % (load/swl) exceeds the THRESHOLD (which will be the value set for the Low Load Lift Counter function Code).

During a log cycle:

- the load is monitored, the peak load seen is continually updated and if no stable load has been recorded then all other data is recorded against peak load.
- a stable load condition will apply when the load remains within a small variation range (set by user through F-Code "Stable Load Variation") for a certain period of time (also an F-Code "Stable Load Time").
- when a stable load is seen, all data (except peak load) are recorded against the stable load.

Data Logging on RCI Systems

- load monitoring continues, the SWL percentage is continually checked against the SWL percentage which was stored, if the percentage increases, a new stable load will be recorded.

A log cycle is completed when:

- the current SWL % drops below the THRESHOLD for a period of time set by the Reset Time Function Code
OR
- the SWL drops to 0 initiating a Type 2 Log cycle.

In either case, the currently performed log will be stored prior to initiating a new cycle.

Type 2 Log- Out of Load Chart / Error conditions

A log cycle is started when:

- SWL drops to 0, implying SWL % is unknown but definitely greater than 110%. In this case the SWL is nominally set to 110% and appears as ">110%" in the logger print out.

During a log cycle:

- the load is monitored and the peak load seen is continually updated (in log 1).
- the radius is monitored and the max. radius seen is continually updated (in log 2).

A log cycle is completed when:

- SWL becomes > 0 (log 1 AND log 2 are stored and condition for starting a type 1 log is checked).

Hence, if a load is lifted within the load chart a single log is performed. If the boom is positioned outside of the load chart, any log cycle in progress is stored and a new cycle begins. During this overload cycle two individual logs will be performed. One log will record the maximum load reading which is observed and the other will record the maximum radius which is observed. It is necessary to perform two logs because it is impossible to know which is a more unsafe condition, a longer radius or a shorter radius but higher load on the hook.

Stable loads are not monitored during out-of-chart/error logging cycles.

Data Logging on RCI Systems

Example Load Lift

Suppose a driver lifts a load and luffs out. If we assume the SWL % generated at the edge of the load chart is sufficient to cause a log to record then as soon as the driver exceeds the maximum radius on the chart, the active log cycle completes and is written to the logger prior to beginning an "out-of-chart" log cycle.

The out-of-chart cycle continues until the driver luffs the crane back into a safe condition. As soon as the safe condition is achieved, the out-of-chart logs (one for max. load and one for max. radius) will be stored to the logger.

Because the crane is now back in a safe condition, a new logging cycle begins. When the driver finally puts this load down (assuming he does not luff off the chart again) the normal log cycle completes and another log is written to the logger.

Hence, although the driver has lifted only a single load and luffed it to several positions, the actual load has been recorded a total of 4 times. This example serves to illustrate that if the crane is continually working on it's outer radius, the Logger will fill very quickly.

It should be noted that if motion cut is connected and the display is not in over-ride, luffing to the out radius limits of the load chart could cause the crane to oscillate as motion cut activates. In this case many logs may be recorded.

Data Logging on RCI Systems

Example Lift Cycles

EXAMPLE 1: Smooth lifting of load

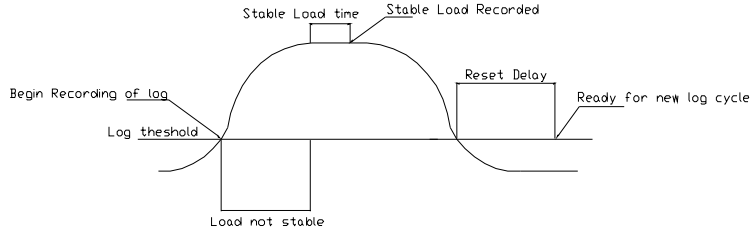

EXAMPLE 2: Grabbing a load

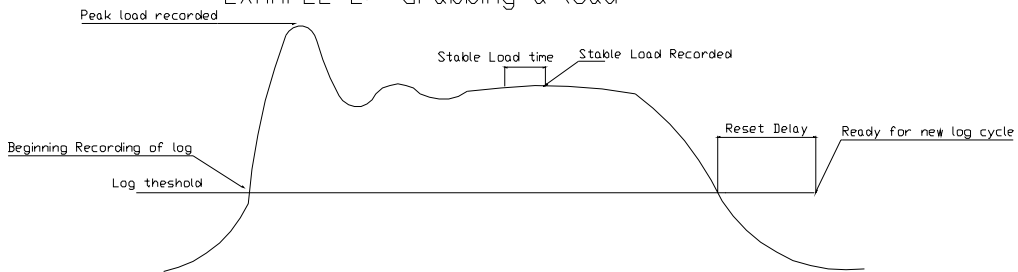

EXAMPLE 3: Partial lift (tension line) then lift load

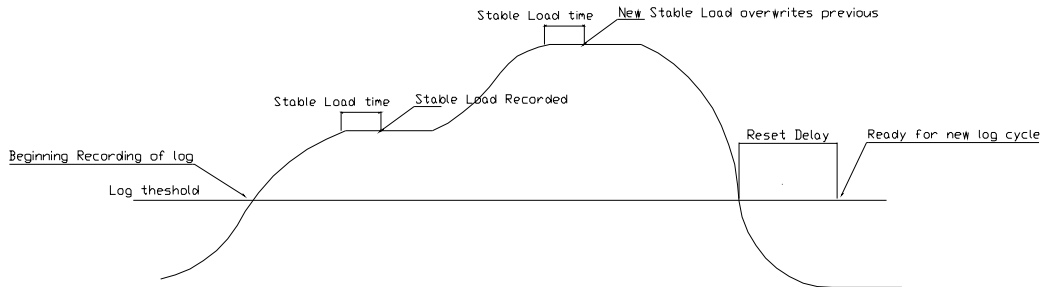

EXAMPLE 4: Grab then drop or Crane Failure

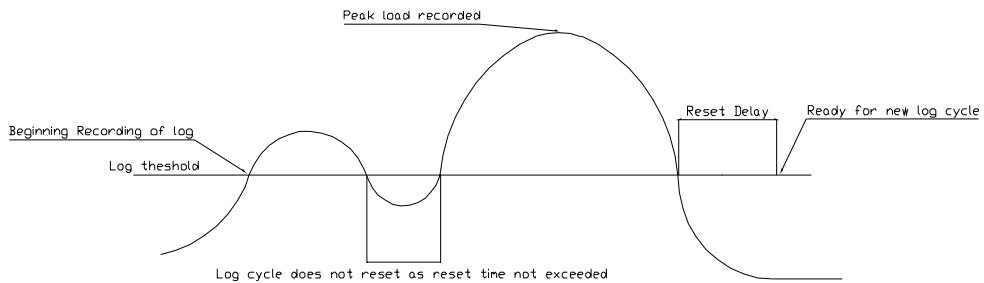

Data Logging on RCI Systems

Accessing the Data Logger

When the RCI System is powered on the normal check routines are performed. If your display has logging enabled then the percentage of the logger which is full is displayed on start up in the LOAD window. The display will show the prompt "=LE=" if the logger is completely empty, otherwise the prompt "LXXX" will show where XXX is the percentage of the logger which is currently filled.

The operator can use two more Function codes for accessing the information stored in the data logger. These Function codes are used for:

Downloading the data logger records to a PC, and
Erasing the content of the data logger

Downloading Data Logger Information

Downloading of data logger records can be performed at any time by attaching the cable provided between the RCI System and a standard PC or laptop and selecting the "Download Log Data" Function Code (refer to Function Codes list at the rear of the Manual for the appropriate code).

Communication Settings

The download is performed as an ASCII file transfer which means any standard terminal emulator software (e.g. simterm, procomm, etc.) or the standard HyperTerminal program of Windows (98, XP, etc.) could be used to receive the information from the RCI System.

Communication Settings for the transfer are:

Baud Rate	= 9600
Data Bits	= 8
Parity	= none
Stop Bits	= 1

Data Logging on RCI Systems

Downloaded Data Format

Each record will be printed in chronological order followed by a summary on the contents of the data logger. If no records have been stored a message to this extent is displayed on the RCI calibration window however, the summary information is still downloaded to the PC.

The summary consists of 6 lines of information as follows:

1. DOWNLOAD PERFORMED (date time)
2. Percentages Changed (date time) ***
3. No. Lifts in range 20% to 40% SWL = xx
4. No. Lifts in range 40% to 65% SWL = xx
5. No. Lifts in range 65% to 90% SWL = xx
6. No. Lifts logged with > 90% SWL = xx

*** Note: Default date if percentages have not been altered from Robway settings is 01/01/96.

The first line simply states the date and time of when the download was performed.

The second line shows the date and time of when the percentage values for the counters and/or the logging percentage were last changed. The default date displayed is the 01/01/96. If the percentages are changed, the new date and time will be stored. This date and time will be maintained until the values are once again altered or calibration data is cleared.

The third, fourth and fifth lines give counts of the total number of lifts performed in the specified regions of SWL %. The percentages shown in this table can of course be changed in Function codes (causing the date in the second line to change as just discussed).

The sixth line gives a count of the number of full logs which have been performed and printed.

The records are printed 1 per line with each field in the record separated by a tab character. This means the resultant file stored on the PC is a tab de-limited text file which is a suitable format for importing into spreadsheet programs such as Microsoft Excel.

Generally spreadsheet programs will automatically recognise the file format as a tab de-limited text file and promptly convert the data into a spreadsheet format. In some cases it may prove necessary to ensure the file is saved with a *.txt* extension name which is the standard extension for ASCII text files.

Data Logging on RCI Systems

Downloading of the logger can be performed any number of times without affecting the contents of the logger. Generally however, after downloading is performed, it is normally desirable to erase the contents of the logger.

Downloading takes approximately 15 seconds per 100 records.

Erasing Data Logger Information

Erasing of data logger records can be performed at any time by accessing the Function Code for "Erasing Log Data" (refer to Function Codes list at the rear of the Manual for the appropriate code).

Erasing the data logger will cause all currently recorded logs to be erased (hence the information can no longer be downloaded) and it also clears the SWL % counters.

In effect, the logger is now empty, however, the old records in the data logger have not really been erased, simply the program log counters have been erased. Hence, in the event that the data logger has been erased but the information has not been saved it is possible to have the data extracted from the logger by sending the display to Robway for analysis.

Data Logging on RCI Systems

Errors in Logger Data

On powering the display the contents of the data logger is checked in three separate operations. In 99% of cases these checks will all pass OK. If however a check fails the state of the logger is immediately questionable. Where possible the operator is given the choice of erasing the suspect data, however, in some instances, the logger will automatically be erased.

If you observe an error and have the option to erase the logger contents, we recommend you don't immediately erase the logger if there is desired information stored there, but rather download the data before then erasing.

These errors should not occur except in extenuating circumstances. If you have trouble with log errors you should immediately report such errors to Robway along with the pertinent information about your display (display serial number & software number)

Firstly, the control structure for the data logger is checked. If an error is found in the control structure for any reason, then the display AUTOMATICALLY ERASES data logger contents (because future logging is not reliable). If this error occurs the message:

LOG CONTROL ERR!
RESETTING LOGGER

is displayed in the calibration window. The only way to retrieve any data in the logger in this case is to send the display to Robway for analysis.

Secondly, the actual data in the logger is checked for errors. In the case that the data is found to be suspect then the message:

LOG DATA ERROR!
<ENTER> to ERASE

is displayed in the calibration window. In this event the user is prompted as to whether to erase the logger contents. Ideally the data should be erased since it is not totally reliable however, the choice is presented so as to give the opportunity to download the information prior to erasing the data (note erasing the data also clears the lift counters).

Lastly, the lift counters are checked for errors. Once again, if an error is found the user has the choice of erasing the counts or ignoring the error.

LOG COUNT ERROR!
<ENTER> to ERASE

If the error is ignored, the count values cannot be relied upon as correct.

Appendix 8.2.

Drawings

<i>DWG 2465</i>	<i>RCI-1502 General Arrangement for Typical Strut Boom Load Moment System</i>
<i>DWG 0279</i>	<i>Dimensional Drawing, RCI-1502 Display</i>
<i>DWG 2459</i>	<i>Dimensional Detail, RCI-1502 Switchbox</i>
<i>DWG 3336</i>	<i>RCI-1502 Switchbox (Version 2) Wiring Detail</i>
<i>DWG 1244</i>	<i>RCI Series Cable Connections</i>
<i>DWG 1099</i>	<i>Electronic Angle Sensor, Dimensional Drawing</i>
<i>DWG 0990</i>	<i>Tension Plate Cell Dimensions</i>
<i>DWG 2934</i>	<i>Dimensional Detail, BB5 Anti-Two-Block Switch</i>
<i>DWG 0667 (3 of 3)</i>	<i>ATB Switch Installation Details, Strut Boom</i>
<i>DWG 2461</i>	<i>Dimensional Details, Proximity Switch (SWIPROX02)</i>
<i>DWG 2462</i>	<i>Dimensional Details, Proximity Switch (SWIPROX03)</i>
<i>DWG 930050 (2)</i>	<i>RCI Slew Switch Mounting</i>

**Note: Drawings of other types of transducers such as special Load Pins (custom-made to suit application) have not been included in the above drawing list. Dimensional details and specification of these transducers will be inserted in the drawing pages if supplied by Robway.*

- SYSTEM NOTES:
PLEASE NOTE THERE ARE OPTIONAL ITEMS WHICH MAY BE SUPPLIED AS PART OF THE SYSTEM, THEY ARE AS FOLLOWS -
- 1) ANTI-TWO BLOCK (ATB) SWITCHES WITH BOB WEIGHTS AND CHAINS, NUMBER OF WHICH CAN VARY DEPENDING ON THE NUMBER OF WINCHES.
 - 2) LOAD PINS, COMPRESSION CELLS OR TENSION CELLS CAN BE USED DEPENDING ON THE APPLICATION REQUIRED. THEY CAN BE FITTED ON EITHER THE MAIN WINCH OR AUXILIARY WINCH.
 - 3) LOAD CABLES CAN VARY IN LENGTH DEPENDING ON THE APPLICATION.
 - 4) PROXIMITY SWITCHES, 3 MAXIMUM.
 - 5) SLIP RING ASSEMBLY WHICH MAY BE USED ON FIXED CABIN CRANES.
 - 6) DATALOGGING FACILITIES.

* CONTACT ROBWAY OFFICE FOR FURTHER DETAILS *

BB5 ATB SWITCH (SWIBB5) (SEE NOTE 1)

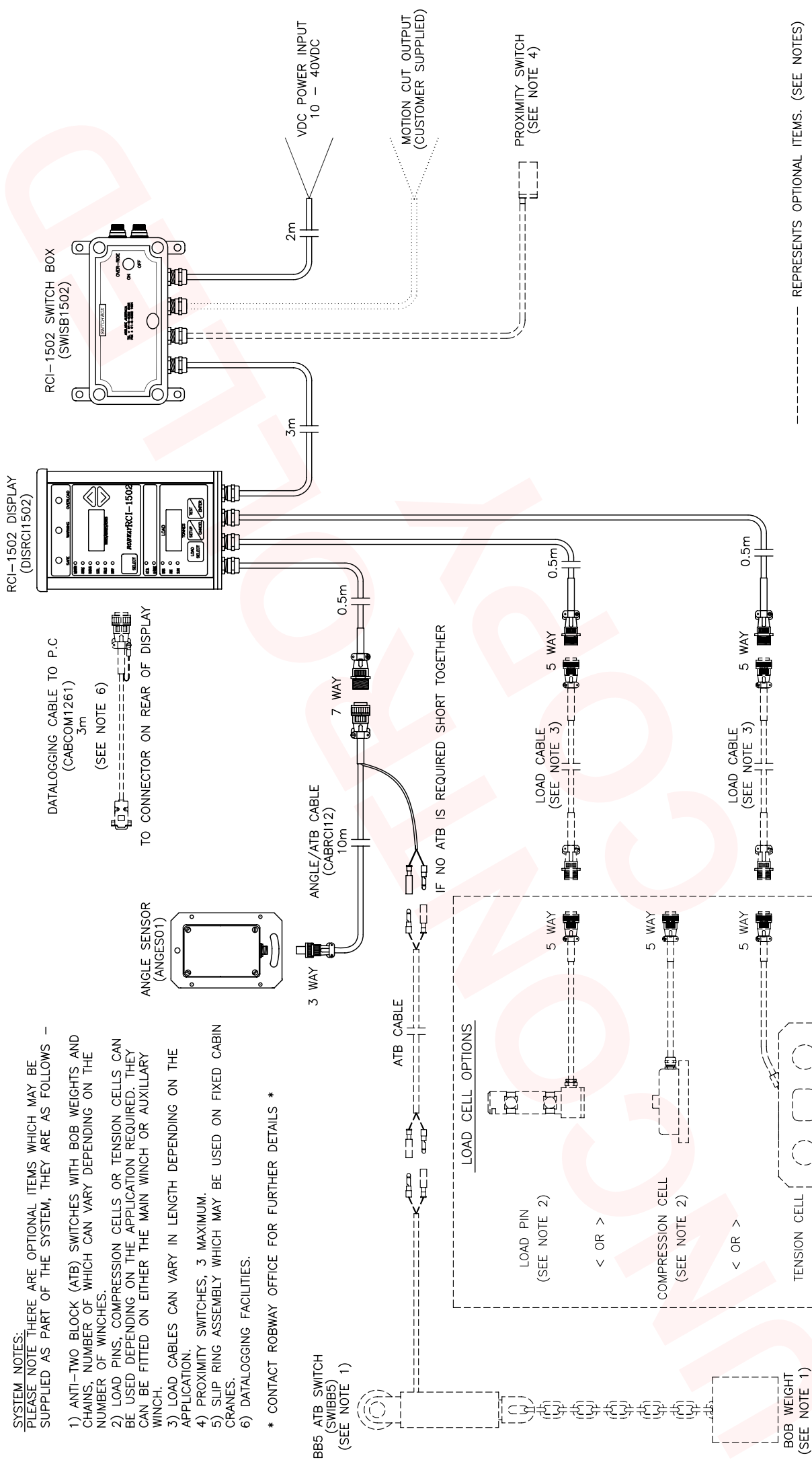

----- REPRESENTS OPTIONAL ITEMS. (SEE NOTES)
..... REPRESENTS CUSTOMER SUPPLIED.

REV	DATE	DESCRIPTION OF CHANGE	APPR'D	PART OF ASSY		PART No:		PROJECT:
1.1	04/06/04	STOCK-CODES ADDED	A.C.	-		-		-
				DRAWN: S. CHAMBERS 12/07/01 APPROVED: A. CANLAS 12/07/01		TITLE: RCI-1502 GENERAL ARRANGEMENT FOR TYPICAL STRUT BOOM LOAD MOMENT SYSTEM		SCALE N/A
				ROBWAY SAFETY SYSTEMS PTY LTD 32 WEST THEBARTON RD THEBARTON 5031 SOUTH AUSTRALIA		DRAWING No: DWG 2465		SHEET 1 OF 1
				TOL: X +/- 1 X.X +/- 0.2 X.XX AS STATED		FILE No: 246501AB.DWG		REV 1.1
				ALL DIMENSIONS ARE IN MILLIMETERS UNLESS OTHERWISE STATED		PHONE +61 8 352 6055 FAX +61 8 352 1684		

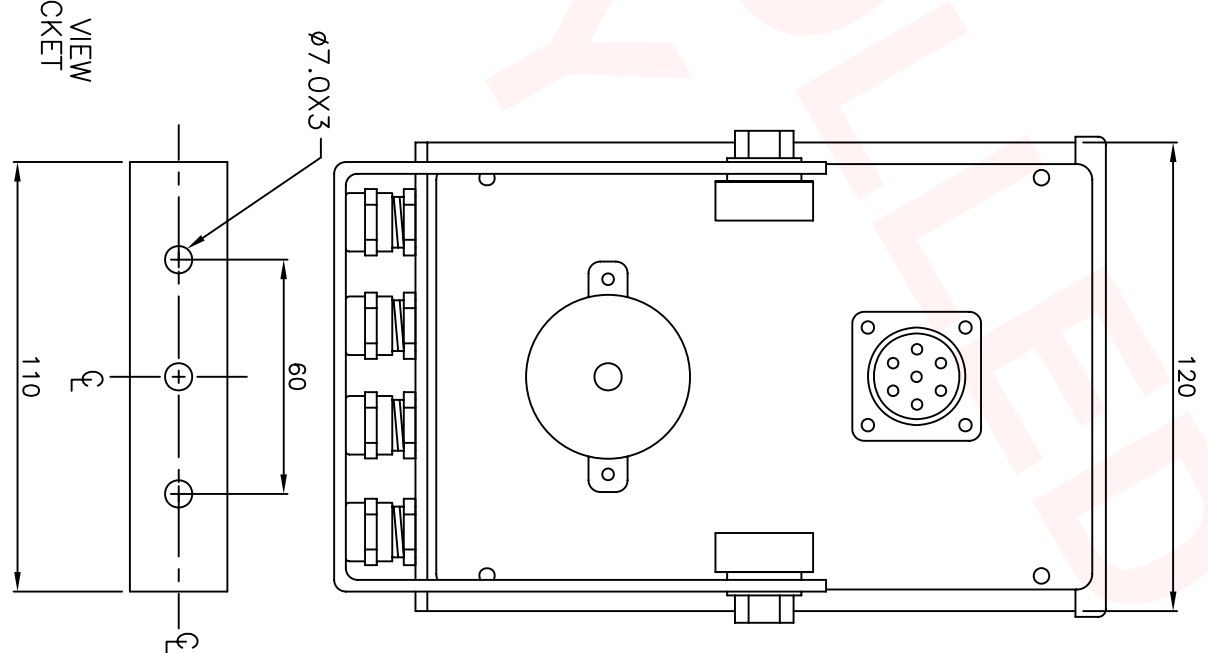
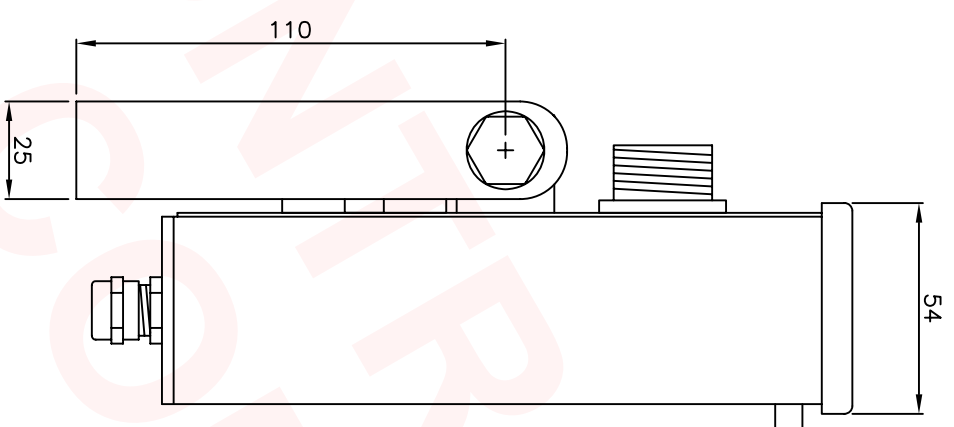
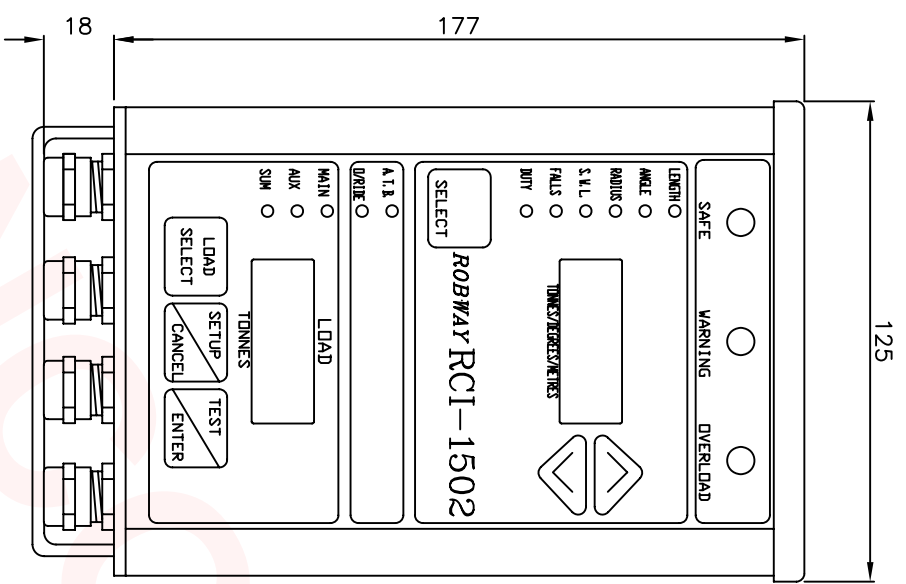
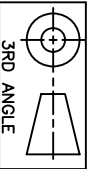

BOTTOM VIEW
OF BRACKET

REV	DATE	DESCRIPTION OF CHANGE	APPR'D
1.0	09/11/00	CONVERTED TO AUTOCAD FORMAT	D.P.

DRAWN	APPROVED	PART OF ASSY
M. OBST		-
07/06/94		

PART No:	PROJECT:
-	RCI-1502 DISPLAY

DO NOT SCALE DRAWING
UNLESS OTHERWISE STATED

TOL: X +/- 1
XX +/- 0.2
XXX AS STATED

ROBWAY SAFETY SYSTEMS PTY LTD
32 WEST THEBARTON RD
THEBARTON 5031
SOUTH AUSTRALIA

PHONE +61 8 8352 6055
FAX +61 8 8352 1684

TITLE:	DRAWING No:	FILE No:	SCALE
DIMENSIONAL DETAILS	DWG 0279	027901AA.DWG	N/A
			SHEET 1 OF 1
			REV 1.0

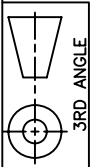

3RD ANGLE

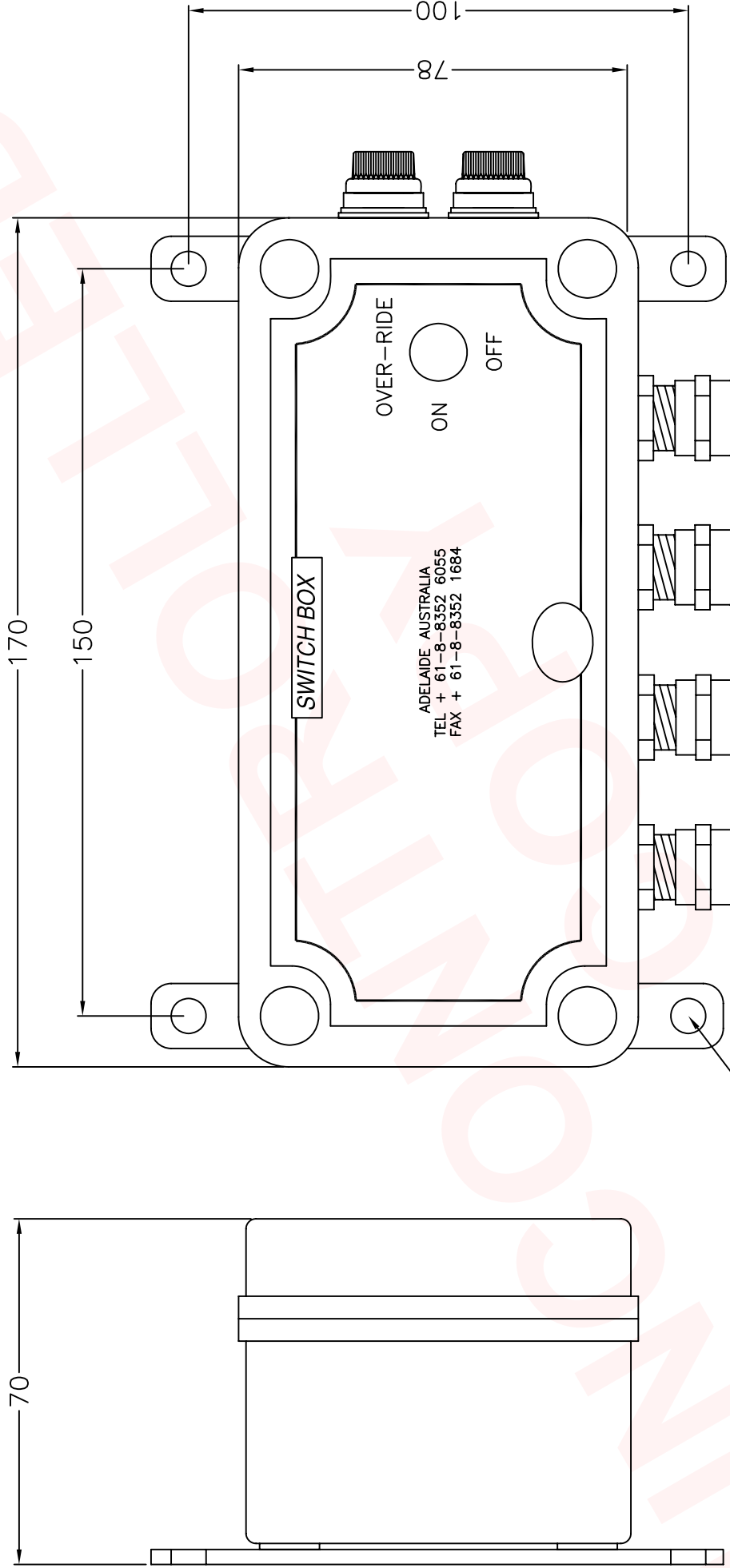

4 X Ø7MM MOUNTING HOLES

REV	DATE	DESCRIPTION OF CHANGE	APPR'D	TOL:		DO NOT SCALE DRAWING ALL DIMENSIONS ARE IN MILLIMETERS UNLESS OTHERWISE STATED		DRAWN APPROVED PART OF ASSY		PROJECT: RCI-1502 SWITCH BOX		SCALE	SHEET	REV
				X	+/- 1			S. CHAMBERS	A. CANLAS	TITLE: DIMENSIONAL DETAIL		N/A	1 OF 1	1.0
				XX	+/- 0.2			10/07/01	10/07/01	DRAWING No: DWG 2459				
				XXX	AS STATED			ROBWAY SAFETY SYSTEMS PTY LTD		FILE No: 245901AA.DWG				
								32 WEST THEBARTON RD THEBARTON 5031 SOUTH AUSTRALIA		PHONE +61 8 352 6055 FAX +61 8 352 1684				

EXTERNAL WARNING LIGHT RELAYS
(RELAY 1, 2 & 3)
EXTERNAL ALARM RELAY
(RELAY 4)
NOTE: RELAYS ONLY INSTALLED UPON
CUSTOMER REQUEST

SHORTING PATCH FOR -
ENABLE EXTERNAL ALARM IN SERIES
WITH RED WARNING LIGHT (RL4)

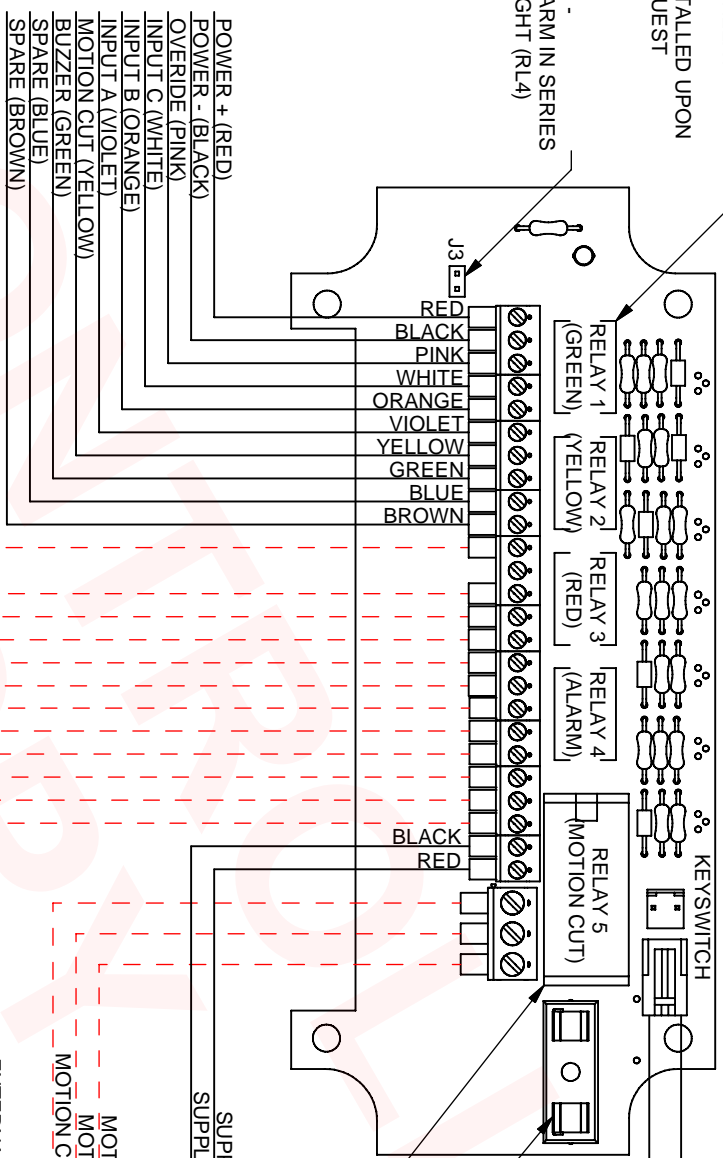

10 CORE DISPLAY INTERFACE
CABLE

- POWER + (RED)
- POWER - (BLACK)
- OVERIDE (PINK)
- INPUT C (WHITE)
- INPUT B (ORANGE)
- INPUT A (VIOLET)
- MOTION CUT (YELLOW)
- BUZZER (GREEN)
- SPARE (BLUE)
- SPARE (BROWN)

INSTALLATION NOTES:
1. THE MOTION CUT OPTION IS RATED FOR 10A 30V MAX. ENSURE THAT THE SOLENOID DOES NOT EXCEED THIS RATING.
2. THE INPUTS MARKED AS 'A', 'B', AND 'C' ARE GENERAL PURPOSE INPUTS. THEIR FUNCTION ARE DEFINED IN THE SOFTWARE DISPATCHED FOR A PARTICULAR APPLICATION. REFER TO THE CONFIGURATION SHEET IN THE MANUAL FOR THEIR DEFINITION.
3. PREVIOUS DEFAULT DEFINITION FOR THE INPUTS WERE:
- INPUT 'A': MAIN DIRECTION, CLOSED = DOWN.
- INPUT 'B': AUXILIARY DIRECTION, CLOSED = DOWN.
- INPUT 'C': SLEW SWITCH, GENERALLY OPEN PRODUCED A DE-RATING.
4. ALL SLEW SWITCHES MUST BE RATED AT 35V OR MORE TO AVOID DAMAGE TO THE SWITCH.

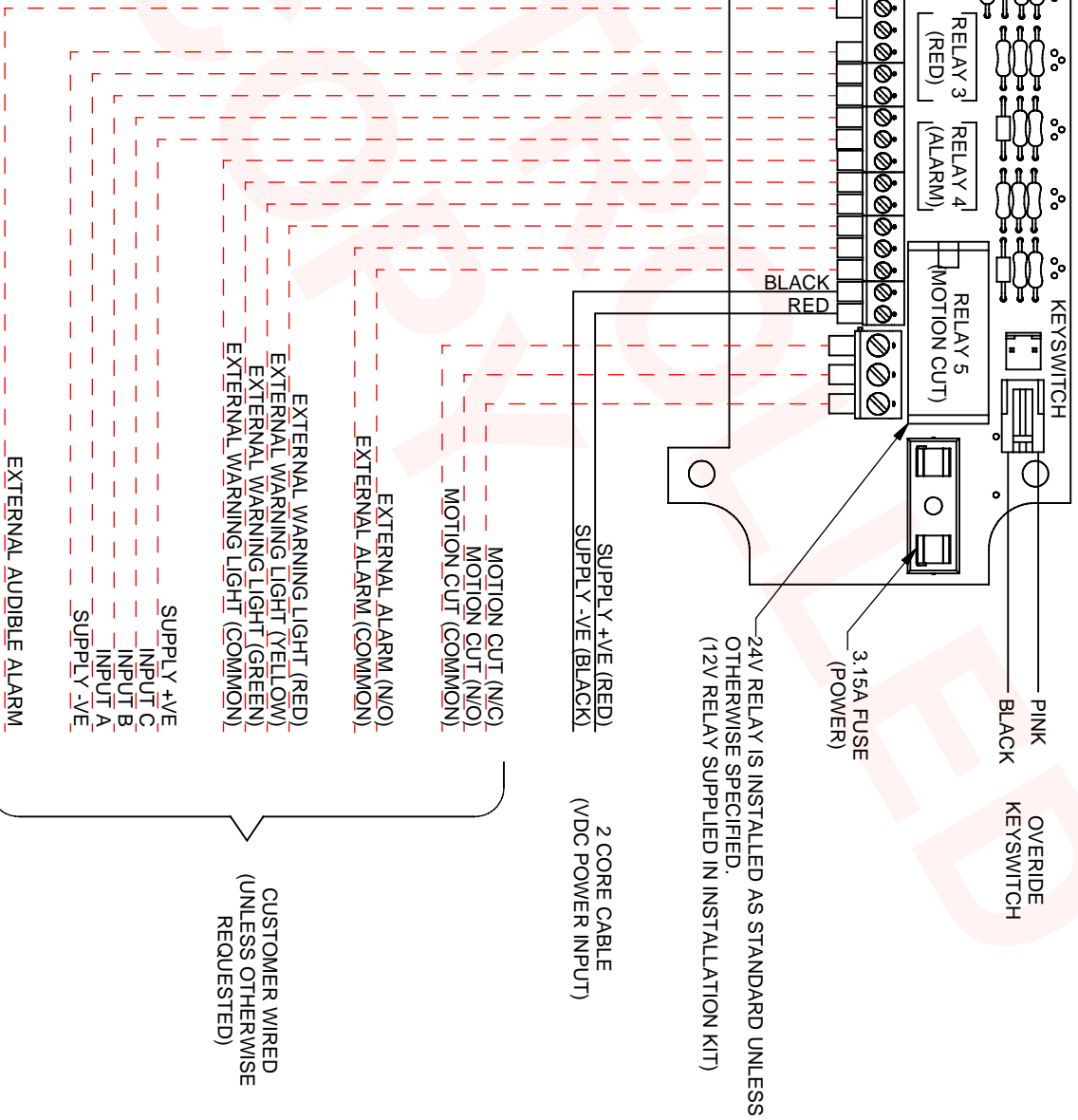
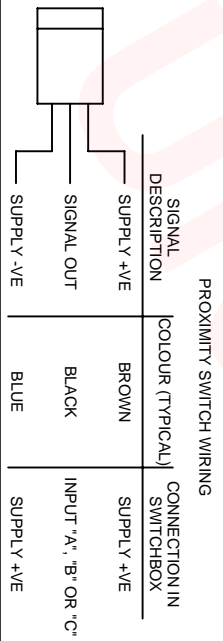

CUSTOMER WIRED
(UNLESS OTHERWISE
REQUESTED)

REV	DATE	DESCRIPTION OF CHANGE	APPR/VD	TOL:
				X, +/1
				XX, +/0.2
				XXX, +/0.02

DO NOT SCALE DRAWING
UNLESS OTHERWISE STATED

©copyright robway 2005

DRAWN BY	APPROVED BY	PART OF ASSY
S. CHAMBERS	J. KOVAL	-
7/02/2006	28/04/2006	

Crane Load Instrumentation
Web : www.robway.com.au

32 West Thebarton Rd
THEBARTON
SOUTH AUSTRALIA 5031
PHONE: +61 8 8238 3500
FAX: +61 8 8352 1684

PART No:	PROJECT:
SWISB1502V2	1502 SWITCHBOX (VERSION 2)
TITLE:	SCALE
WIRING DETAIL	N/A
DRAWING No:	SHEET
DWG 3336	1 OF 1
FILE No:	REV
333601AA.idw	1.0

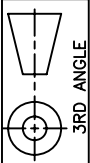

3RD ANGLE

7-WAY CONNECTOR		LENGTH/ANGLE AND ATB CABLE	REELING DRUM CONNECTOR	ANGLE CABLE WITH ATB	ANGLE CABLE
PIN	DESCRIPTION	COLOUR	COLOUR	COLOUR	COLOUR
A	EXCITATION +VE	RED	RED	RED	RED
B	LENGTH SIGNAL	BLUE	BLUE	BLACK	BLACK
C	EXCITATION -VE	BLACK	BLACK	GREEN	GREEN
D	NOT USED	YELLOW	YELLOW	RED (ATB)	SCREEN
E	ANGLE SIGNAL	WHITE	WHITE	SCREEN/BLACK (ATB)	SCREEN
F	ATB SIGNAL	GREEN	GREEN		
G	SCREEN	SCREEN	SCREEN		

5-WAY LOAD CONNECTOR		COLOUR	DESCRIPTION
A	BLACK	EXCITATION -VE	
B	WHITE	SIGNAL -VE	
C	RED	EXCITATION +VE	
D	GREEN	SIGNAL +VE	
E	SCREEN	SCREEN	

3-WAY ANGLE CONNECTOR		COLOUR	DESCRIPTION
A	RED	EXCITATION +VE	
B	GREEN	ANGLE SIGNAL	
C	BLACK	EXCITATION -VE	

NOTE:

- FOR ANGLE CABLE WITH ATB, PIN 'B' IN THE 7-WAY CONNECTOR IS NOT CONNECTED
- FOR ANGLE CABLES ONLY PINS 'B', 'D' AND 'F' IN THE 7-WAY CONNECTOR ARE NOT CONNECTED

REV	DATE	DESCRIPTION OF CHANGE	APPR'D	DRAWN	APPROVED	PART OF ASSY	PART No:	PROJECT:
				M. TURNER	M. OBST	-	-	-
				25-10-96	27/02/97			
				TOL: X +/- 1 X.X +/- 0.2 X.XX AS STATED		TITLE: RCI SERIES CABLE CONNECTIONS		
				DO NOT SCALE DRAWING ALL DIMENSIONS ARE IN MILLIMETERS UNLESS OTHERWISE STATED		DRAWING No: DWG 1224 FILE No: 122401AA.DWG		
				ROBWAY SAFETY SYSTEMS PTY LTD 32 WEST THEBARTON RD THEBARTON 5031 SOUTH AUSTRALIA		SCALE N/A SHEET 1 OF 1 REV 1.0		
				PHONE +61 8 352 6055 FAX +61 8 352 1684				

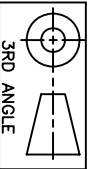

90° TO BOOM
CENTRELINE

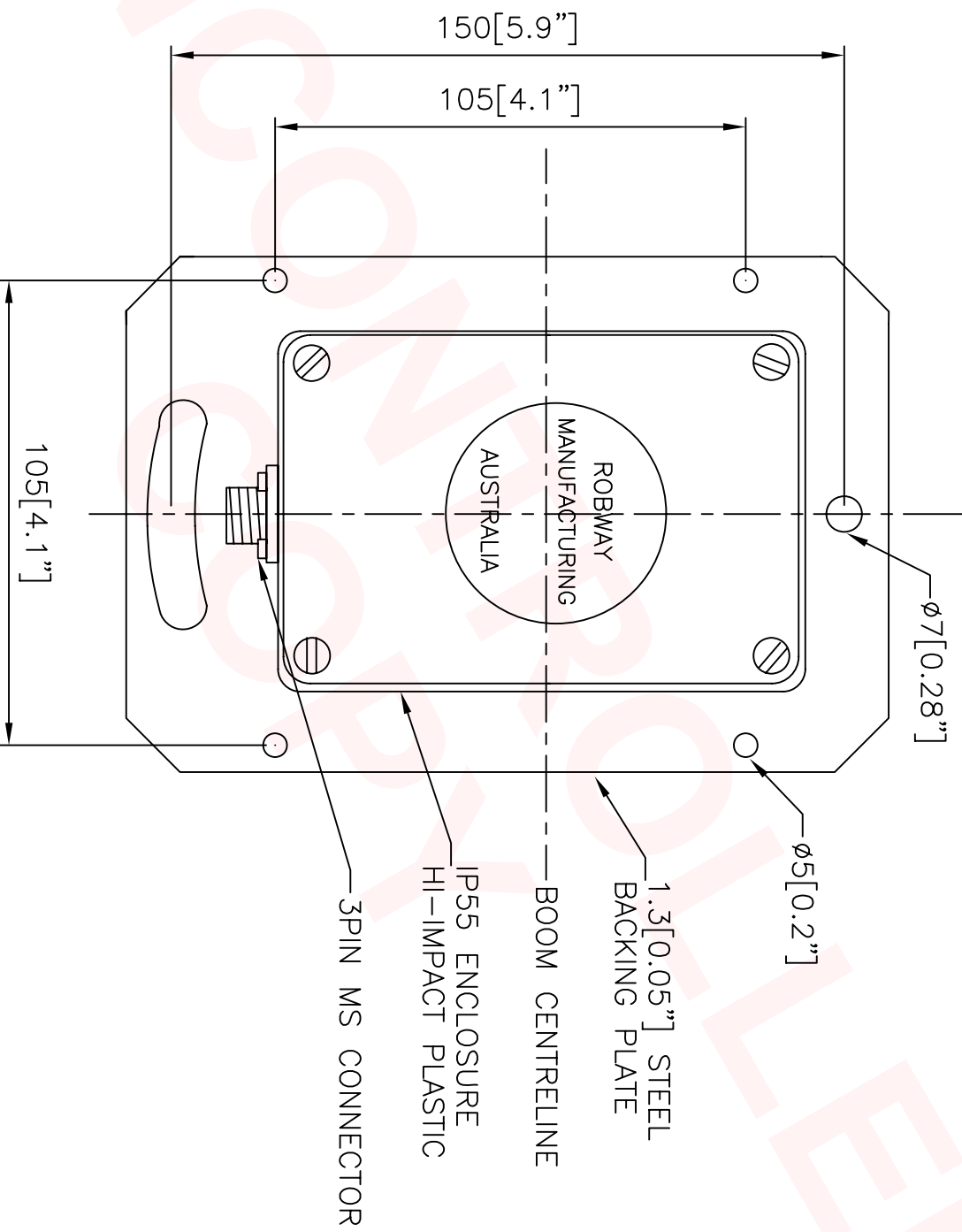

REV	DATE	DESCRIPTION OF CHANGE	APPR'D	DRAWN		APPROVED	PART OF ASSY	PART No:	PROJECT:	SCALE
1.1	04/11/98	REFER TO DR#564	M.O.	M. TURNER	M. OBST					N/A
				27/02/97		27/02/97				SHEET
										1 OF 1
										REV
										1.1

TOL: X +/- 1
 XX +/- 0.2
 XXX AS STATED

DO NOT SCALE DRAWING
 ALL DIMENSIONS ARE
 IN MILLIMETERS [INCHES]
 UNLESS OTHERWISE STATED

DRAWN: M. TURNER
 APPROVED: M. OBST
 27/02/97

PART OF ASSY: -

ROBWAY SAFETY SYSTEMS PTY LTD
 32 WEST THEBARTON RD
 THEBARTON 5031
 SOUTH AUSTRALIA

PHONE +61 8 352 6055
 FAX +61 8 352 1684

TITLE: ELECTRONIC ANGLE SENSOR
 DIMENSIONAL DRAWING

DRAWING No: DWG 1099
 FILE No: 109901AB.DWG

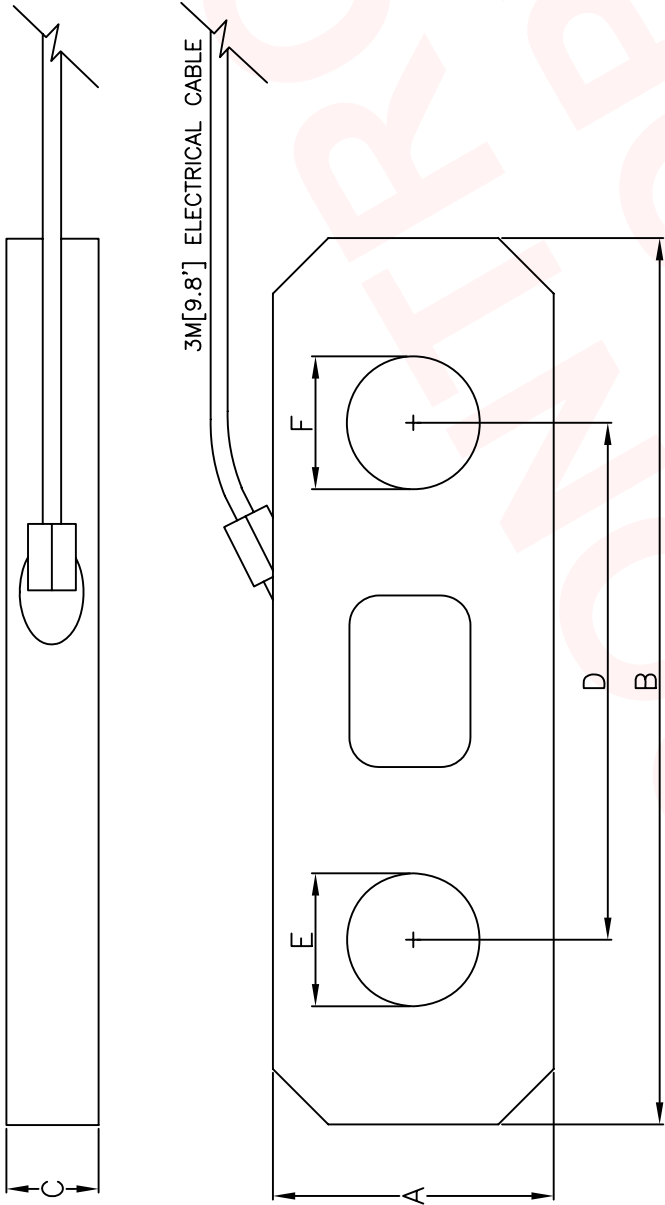
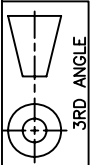

GENERAL SPECIFICATIONS

LINEARITY: 0.15% NOMINAL
 REPEATABILITY ERROR: <0.10%
 HYSTERESIS: <0.10%
 CREEP: <0.10%
 OUTPUT: 2MV/V NOMINAL
 EXCITATION: 15VDC. REC MAX.
 ISOLATION: >2000 MEGOHMS AT 50VDC
 OVERLOAD: 150%
 NO ELECTRICAL DAMAGE: >400%
 ULTIMATE: <0.005% /DEG C
 TEMPERATURE EFFECTS: <0.005% /DEG C
 ON ZERO: -10 TO +70 DEG C
 ON SPAN: IP68 FULLY ENCAPSULATED
 COMPENSATION RANGE: SEALING:

LOAD CELL TYPE	A		B		C		D		E		F	
	MM	INCHES	MM	INCHES	MM	INCHES	MM	INCHES	MM	INCHES	MM	INCHES
6MT	48	1.9	155	6.1	25	1.0	100	3.9	31	1.2	31	1.2
10MT	78	3.1	260	10.2	25	1.0	158	6.2	42	1.7	42	1.7
15MT	78	3.1	260	10.2	25	1.0	158	6.2	42	1.7	42	1.7
30MT	102	4.0	300	11.8	38	1.5	168	6.6	42	1.7	42	1.7
56MT	146	5.7	457	18.0	37	1.4	316	12.4	76	3.0	76	3.0
91MT	174	6.9	560	22.0	73	2.9	390	15.4	79	3.1	79	3.1

REV	DATE	DESCRIPTION OF CHANGE	DRAWN		APPROVED		PART OF ASSY		PART No:	PROJECT:	
1.1	06/05/98	REFER TO DR#480	M. TURNER	M. OBST	M. TURNER	M. OBST	-		-	-	
1.2	05/11/98	REFER TO DR#564	08/03/96	15/01/97	-		-		-	-	
			TOL: X +/- 1 XX +/- 0.2 XXX AS STATED				TITLE: TENSION PLATE CELL DIMENSIONS FOR 6, 10, 15, 30, 56, 91MT CELLS				
			DO NOT SCALE DRAWING ALL DIMENSIONS ARE IN MILLIMETERS UNLESS OTHERWISE STATED				DRAWING No: DWG_0990 FILE No: 099001AC.DWG				
			ROBWAY SAFETY SYSTEMS PTY LTD 32 WEST THEBARTON RD THEBARTON 5031 SOUTH AUSTRALIA				SCALE N/A SHEET 1 OF 1 REV 1.2				

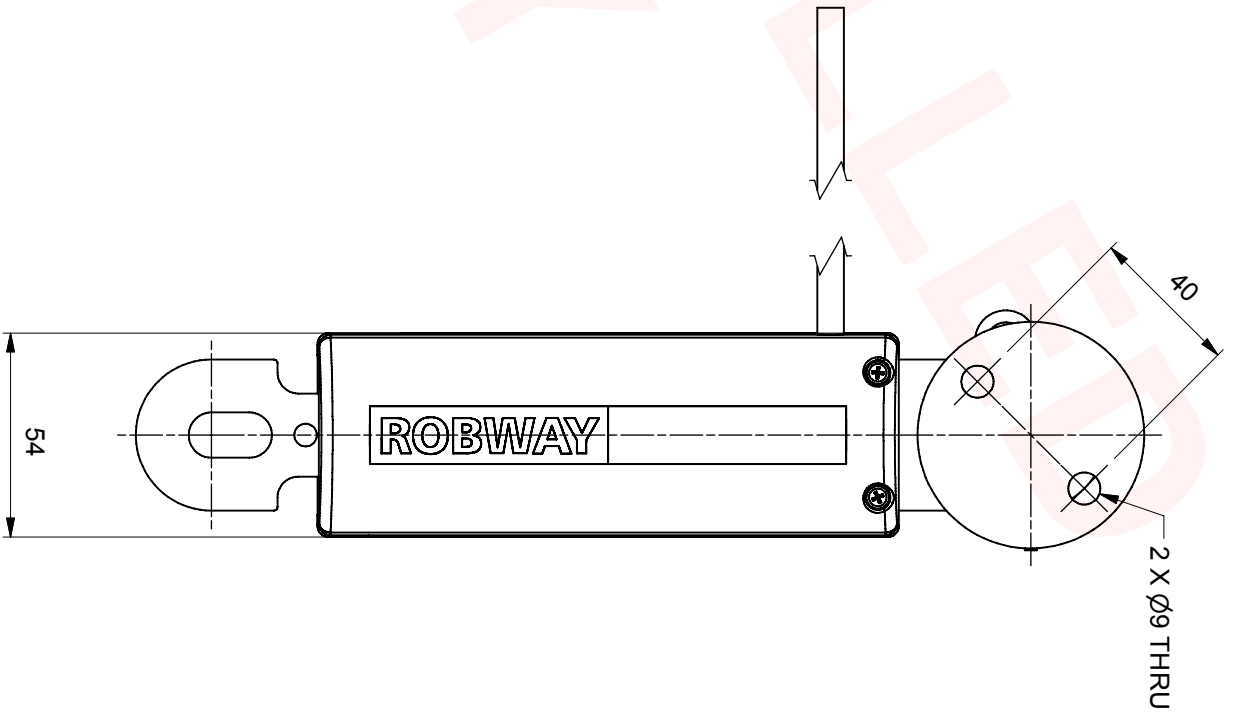
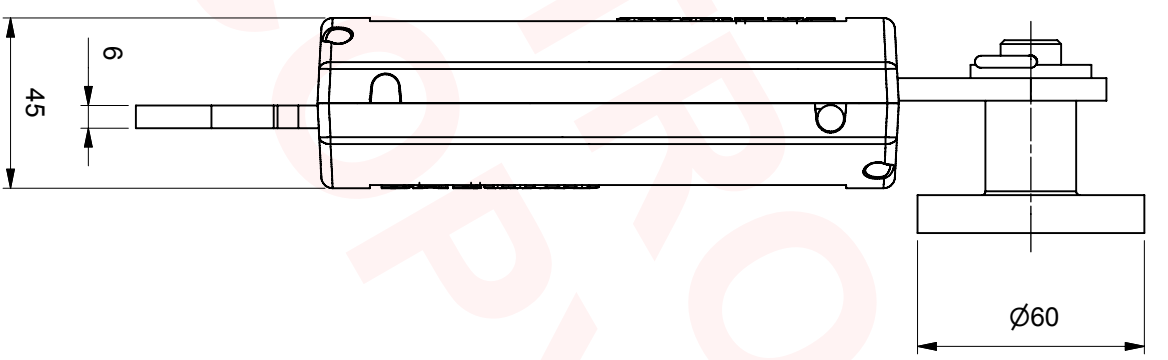
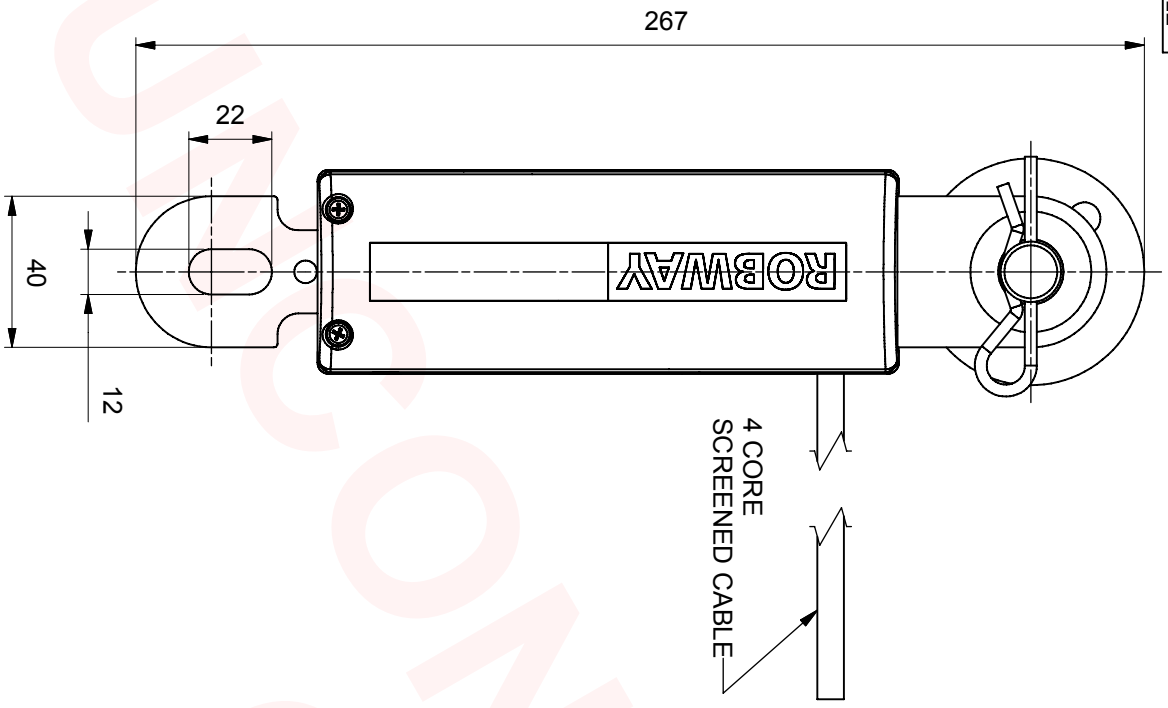
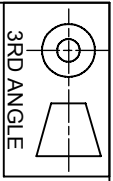

REV	DATE	DESCRIPTION OF CHANGE	APPR/V/D

TOL: X +/1
 XX +/0.2
 XXX +/0.02

DO NOT SCALE DRAWING
 UNLESS OTHERWISE STATED

©copyright robway 2005

DRAWN BY	APPROVED BY	PART OF ASSY
S. CHAMBERS	A. CANLAS	-
19/04/2005	19/04/2005	

Crane Load Instrumentation
 web : www.robway.com.au

ROBWAY

32 West Thebarton Rd
 THEBARTON
 SOUTH AUSTRALIA 5031
 PHONE: +61 8 8238 3500
 FAX: +61 8 8352 1684

PART No:	PROJECT:	SCALE
SWISBB5	BB5 ATB SWITCH	N/A
TITLE: DIMENSIONAL DETAIL		
DRAWING No: DWG 2934	FILE No: 293401AA.idw	SHEET 1 OF 1
		REV 1.0

STRUT BOOM SINGLE CORE PAYOUT CABLE APPLICATION

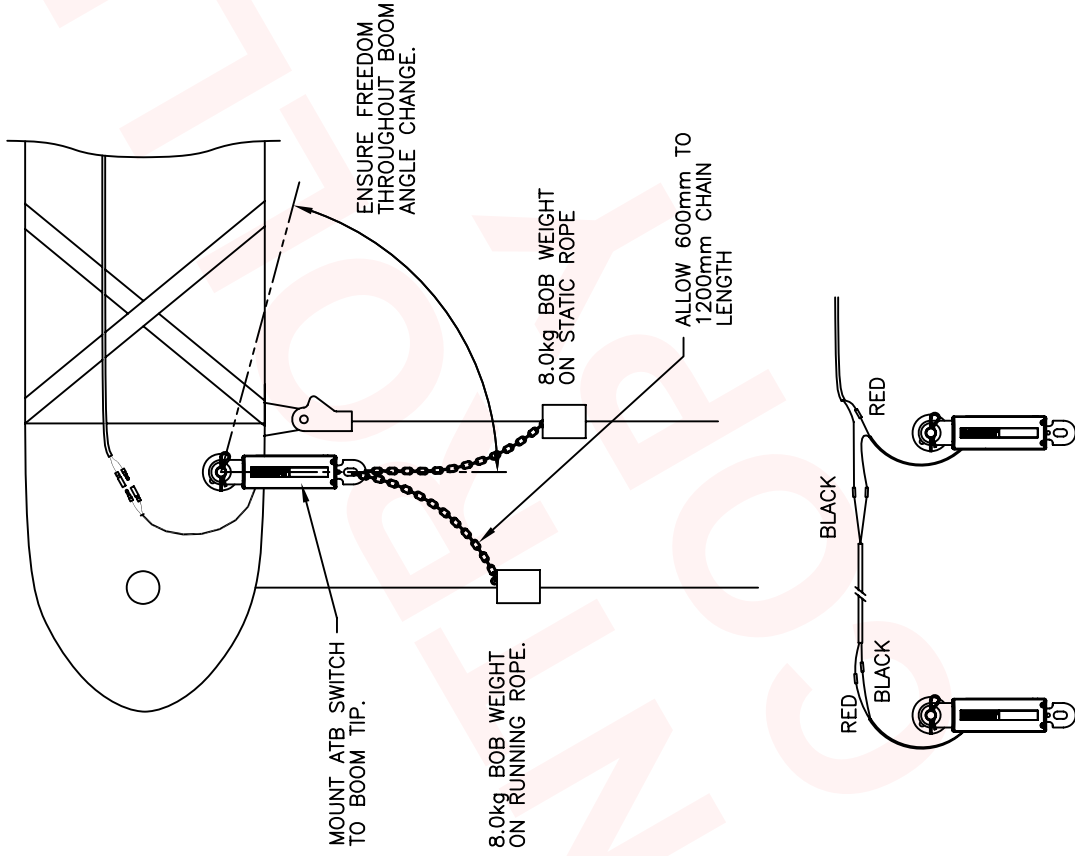

ATB SWITCH CONNECTION FOR MAIN AND FLY

REV	DATE	DESCRIPTION OF CHANGE	APPR'D	TOL:	DO NOT SCALE DRAWING ALL DIMENSIONS ARE IN MILLIMETERS UNLESS OTHERWISE STATED	DRAWN	APPROVED	PART OF ASSY	PART No:	PROJECT:
1.1	03/08/05	REFER TO DR#421	A.C.	X +/- 1 X.X +/- 0.2 X.XX AS STATED		S. CHAMBERS 10/07/01	A. CANLAS 10/07/01	—	—	—
								ROBWAY SAFETY SYSTEMS PTY LTD		
								32 WEST THEBARTON RD THEBARTON 5031 SOUTH AUSTRALIA		
								PHONE +61 8 8352 6055 FAX +61 8 8352 1684		
								INSTALLATION DETAILS		
								DWG 0667		
								FILE No: 066701AB.DWG		
								SCALE N/A		
								SHEET 3 OF 3		
								REV 1.1		

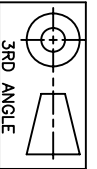

3RD ANGLE

WIRING DETAIL
(NPN - NORMALLY OPEN)

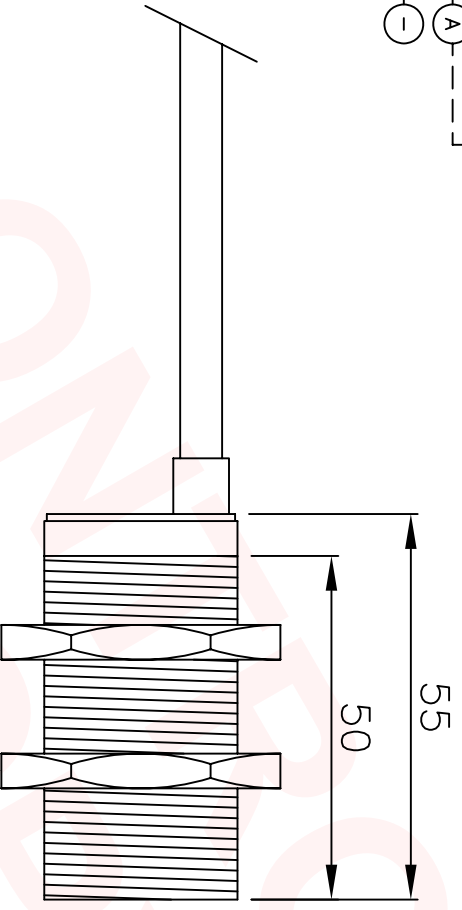
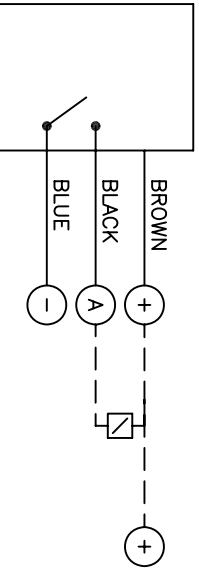

2 X LOCKNUTS
SUPPLIED WITH PROX.
SWITCH.

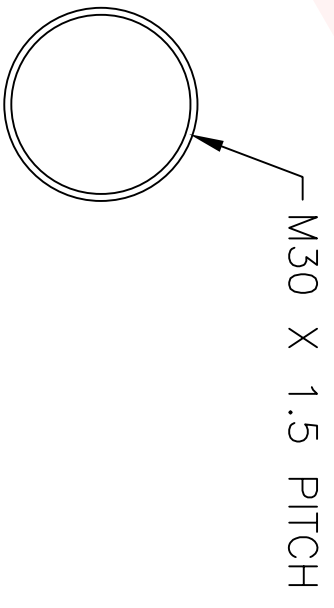

REV	DATE	DESCRIPTION OF CHANGE	APPR'D							
				TOL: X +/- 1 XX +/- 0.2 XXX AS STATED		DO NOT SCALE DRAWING UNLESS OTHERWISE STATED				
DRAWN			APPROVED			PART OF ASSY				
S. CHAMBERS			A. CANLAS			-				
10/07/01			10/07/01							
ROBWAY SAFETY SYSTEMS PTY LTD 32 WEST THEBARTON RD THEBARTON 5031 SOUTH AUSTRALIA PHONE +61 8 8352 6055 FAX +61 8 8352 1684										
PART No: SWIPROX02					PROJECT: PROXIMITY SWITCH					
TITLE: DIMENSIONAL DETAILS										
DRAWING No: DWG 2461			FILE No: 246101AA.DWG							
SCALE N/A										SCALE 1 OF 1
SHEET 1 OF 1										REV 1.0

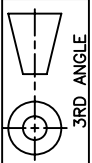

3RD ANGLE

WIRING DETAIL

(PNP – NORMALLY OPEN / NORMALLY CLOSED)

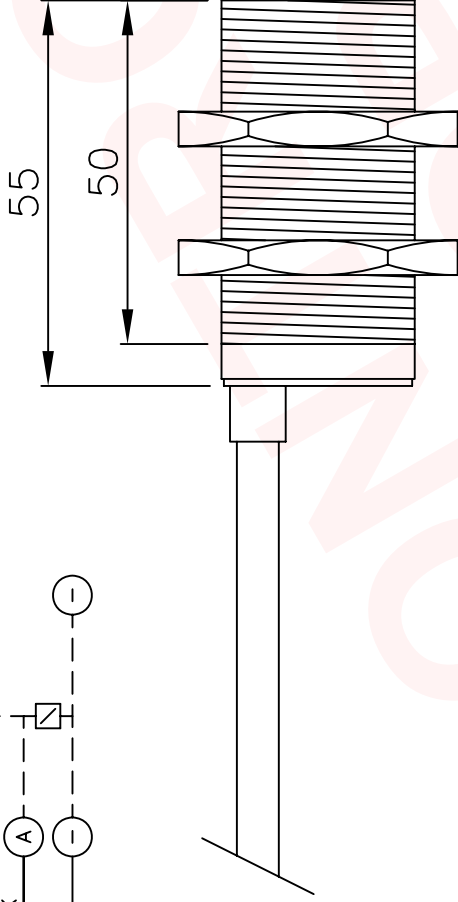
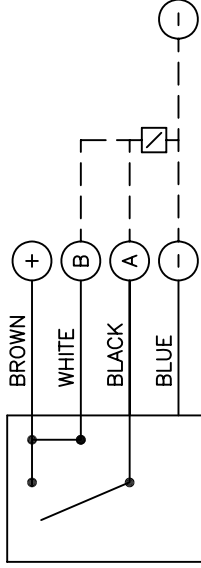

M30 X 1.5 PITCH

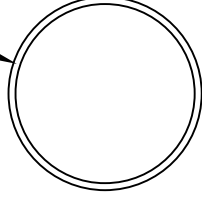

2 X LOCKNUTS
SUPPLIED WITH PROX.
SWITCH.

REV	DATE	DESCRIPTION OF CHANGE	APPR'D	TOL:	DO NOT SCALE DRAWING ALL DIMENSIONS ARE IN MILLIMETERS UNLESS OTHERWISE STATED	DRAWN	APPROVED	PART OF ASSY	PART No:	PROJECT:	SCALE	SHEET	REV
				X: +/- 1		S. CHAMBERS		—	SWIPROX03	PROXIMITY SWITCH	N/A	1 OF 1	1.0
				+/- 0.2		10/07/01			TITLE:	DIMENSIONAL DETAILS			
				X.XX AS STATED		ROBWAY SAFETY SYSTEMS PTY LTD			DRAWING No:	FILE No:			
						32 WEST THEBARTON RD THEBARTON 5031 SOUTH AUSTRALIA			DWG 2462	246201AA.DWG			
						PHONE +61 8 8352 6055 FAX +61 8 8352 1684							

RCI SLEW SWITCH MOUNTING (WHERE REQUIRED)

TO RCI SYSTEM KEYSWITCH BOX OR CONTROL UNIT

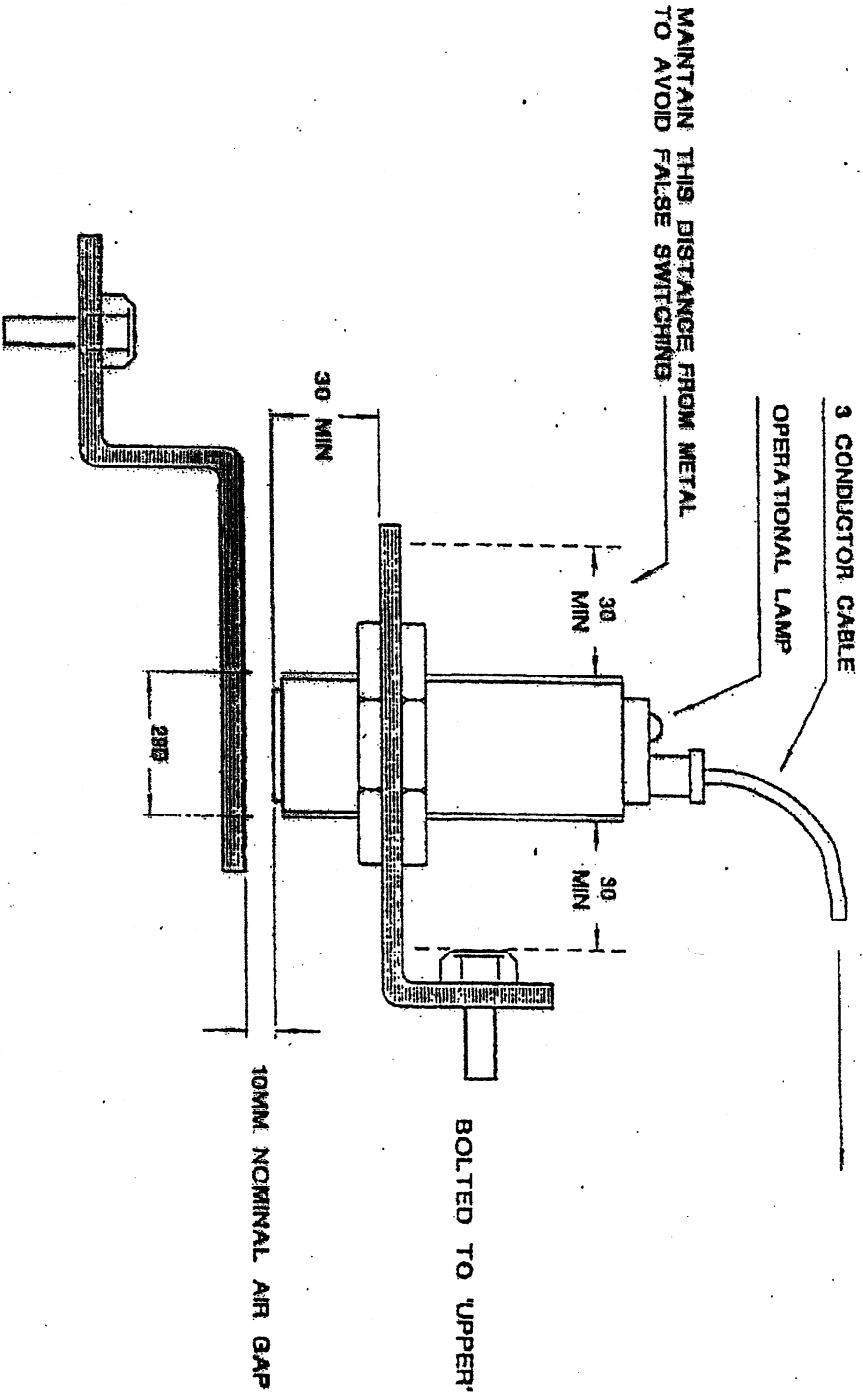

BOLTED TO CARRIER

NOTE 1 SUGGEST SCHMERSAL BRAND TYPE IFL 10-30-10Z1PKG
NOTE 1 PROXIMITY SWITCH MAY BE MOUNTED HORIZONTAL

ROBBY SAFETY SYSTEMS P/L CR 382 003

DRAWN: JAW	CHECKED:	DATE: 0-11-93
CUSTOMER: ICI MANUALS		EXAMINED/INCD
ICI SLEW SWITCH MOUNTING		DWG: 930050
FILE NO: 930050		REV: No

Typical Slew/Proximity Switch Application

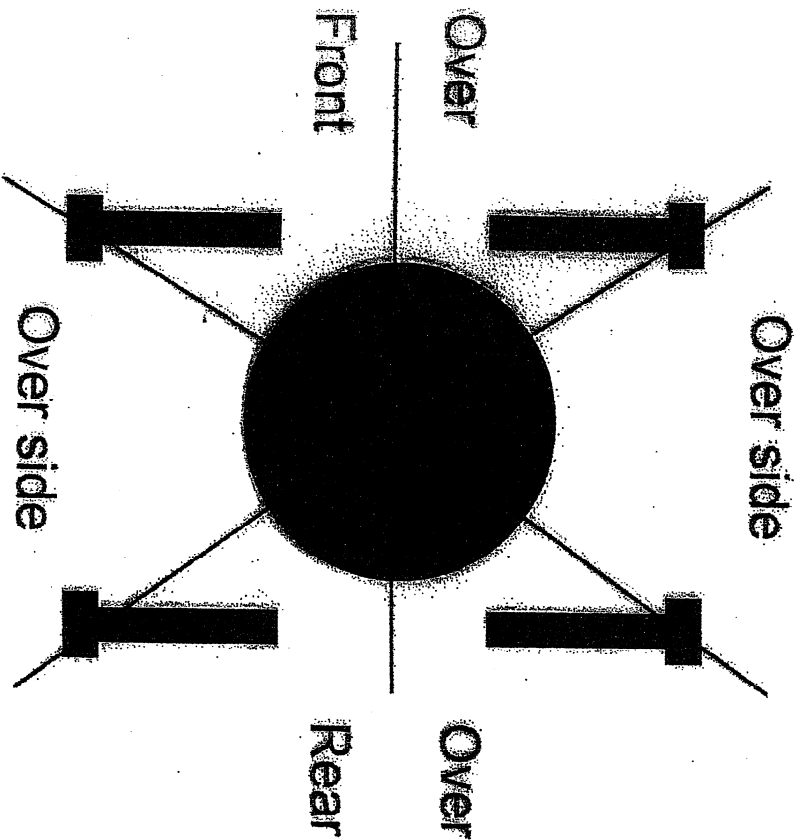

Switch 1 —●—●—
 opens when over-front

Switch 2 —●—●—
 opens when over-side

Therefore a truth table is:

SW1	SW2	condition
C	C	over-rear
C	O	over-side
O	O	over-front
broken cables over-front, least capacity.		

RCI-1502 CALIBRATION PROCEDURE FOR LOAD MOMENT SYSTEMS WITH USER CONFIGURABLE OPTIONS

1. Turn the **OVER-RIDE** key on,
2. Press and hold **SETUP** until **F-xx** appears on top digital display,
(where xx is the code for last calibration function)
3. Use **UP/DOWN** keys to select function then press **ENTER** to accept,
4. Use **UP/DOWN** keys to set new value then press **ENTER** to accept,
5. Repeat steps 2 and 3 for any other functions if required,
6. Select **F-00** or press **CANCEL** to exit calibration mode.

NOTE

Once in calibration mode you may use CANCEL key to cancel any function.