

# Ex Safety and Installation Instructions GS007 Series Sensors



Load Systems International  
2666 Boul du Park-Technologique  
Québec QC G1P 4S6  
Canada  
[www.loadsystems.com](http://www.loadsystems.com)

## SCOPE

This Ex instruction manual must be read and used by qualified personnel during system design and installation of the GS007 Series Sensors. These instructions are provided as an addendum to the standard product manuals.



## Warning

### **SPECIAL CONDITIONS FOR SAFE USE, INSTALLATION, OPERATION, AND MAINTENANCE**

The GS007 Series Sensors are Group IIC Ex ia certified intrinsically safe apparatus which may be installed in Hazardous Area Zone 0, Zone 1 or Zone 2.

The combination of a GS007 Series Sensors with a GDxxx Series Line Rider Tensiometer frame must be considered an "assembly" in the sense of Directive 2014/34/EU. The GDxxx Series Line Rider Tensiometers have **NOT** undergone a conformity assessment procedure. Therefore, a GS007 + GDxxx assembly **CANNOT** be considered to be in conformity with the Essential Health and Safety Requirements of the Directive and is **NOT** to be installed in a hazardous area.

Battery replacement must not be performed in the presence of a potentially explosive atmosphere

The GS007 Series Sensors must be operated within environmental limitations.

The GS007 Series Sensors must only be installed by qualified personnel in accordance with the relevant international installation standards

The GS007 Series Sensors cannot be repaired by the end user thus any units exhibiting a failure must be returned to the manufacturer.

## SAFETY ANALYSIS

In a system safety analysis, always check that the Hazardous Area / Hazardous location devices conform to the relevant standards.

## INSTALLATION

The GS007 Series Sensors are fully self-contained and require no special grounding techniques. They have an IP rating of 65 with fully potted internal electronics and are intended to be mounted outdoors.

## OPERATION

The GS007 Series Sensors are battery-powered stand-alone devices with no interconnecting cables.

Proper operation of the GS007 Series Sensors is indicated by a green LED flashing periodically. Failure of the LED flashing can indicate either a dead battery or no receiver is present within RF Range.

## STARTUP

The GS007 Series Sensors contain a battery and will automatically power on and off when a remote receiver is detected, thus there are no power cables or power switches.

When a GS007 Series Sensor detects a remote receiver the green LED will flash on and off periodically. This indicates successful communication with the remote receiver.

If there is not a green LED flashing periodically it means either there is not a remote display turned on or the internal battery is dead.

**BATTERY REPLACEMENT PROCEDURE**

Only the battery specified here may be used as a replacement:

LSI ORDER CODE	MANUFACTURER	MANU PART NUMBER	DESCRIPTION
TB015	TADIRAN	TL5930	3.6V 19Ahr Lithium D-cell

Battery replacement is identical to the GCxxx Load Cells as follows:

**IMPORTANT! Protect the interior of the sensor from dirt and humidity at all times.**

1. Unscrew the two allen screws about a quarter of an inch.
2. Insert a flat bladed screwdriver in the battery cover notch to pry the box away from the mounting plate. The silicone seal may cause some resistance.

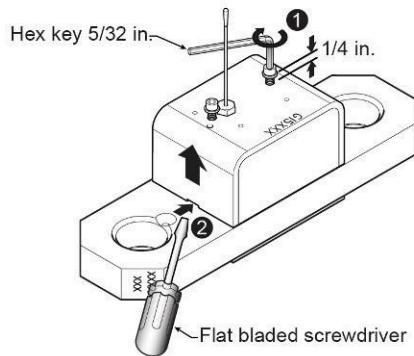

*Figure: Remove the sensor box from the mounting plate*

3. The data wires of a load cell may be disconnected to facilitate battery replacement.

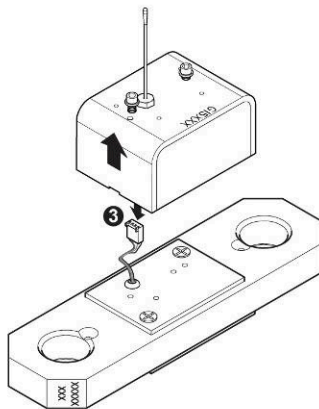

*Figure: Disconnect the data wires*

4. Remove the battery by hand.
5. Remove the remaining silicone from both the box and the mounting plate.
6. Install the new battery: insert the positive end and then push in the direction of the positive pole.
7. Reconnect the data wires if disconnected.

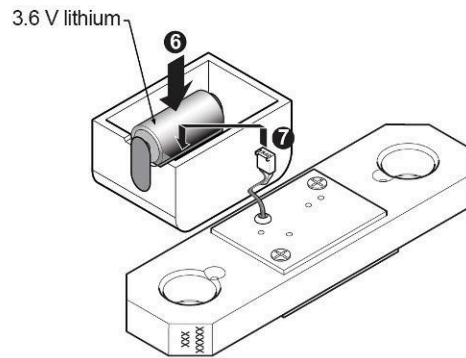

*Figure: Install the new battery and reconnect the data wires*

8. Apply a non-corrosive RTV silicone all around the edge of the mounting plate to create a new seal without bubbles or breaks.

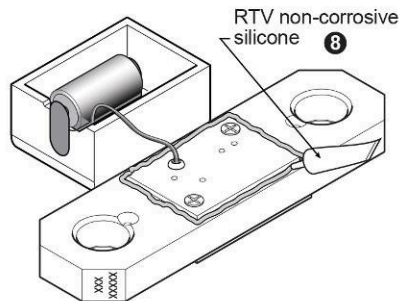

*Figure: Apply non-corrosive RTV silicone*

9. Reposition the box over the mounting plate and screw in the hex screws. **Do not overtighten.**

## Ex Safety and Installation Instructions GS007 Series Sensors



### STORAGE

The ambient temperature may exceed the lower operating temperature limit of -20°C without damage for limited periods of time such as may be experienced during air transport. The lower operating temperature limit is not to be exceeded during operation.



### DISPOSAL

Please separate and dispose of electronic goods responsibly and follow guidelines and regulations for your region.

### SPECIFICATIONS

Compliance	ATEX Certificate Number	Sira 14ATEX2332X
	Temperature Classification	T4, $-20^{\circ}\text{C} \leq T_{\text{amb}} \leq +75^{\circ}\text{C}$
Product Markings	ATEX	Ex ia IIC T4 $-20^{\circ}\text{C} \leq T_{\text{a}} \leq +75^{\circ}\text{C}$ Sira 14ATEX2332X  II 1 G  0891
Quality Assurance Notification		TRAC12QAN0007
LED Indicators	Communicating	Green
Power Supply	Voltage	3.6 VDC nominal
	Current	30 milliamps
Physical	Dimensions	165mm x 70mm x 60mm (l x w x h)
	Weight	1.0 kg
	Material	AISI 304
	IP Rating	65
Environmental	Operating Temperature	-20°C to +75°C
	Humidity	0 to 99%
FCC ID	(GS007-xx-ATEX-10 models only)	QVBGS000

**INSTALLATION CONTROL DRAWING**

Hazardous Area	Hazardous Area	Safe Area
<p>Ex ia IIC T4 -20°C &lt; Tamb &lt; +75°C Sira 14ATEX2332X</p>	<p>Ex d IIB T4 -30°C &lt; Tamb &lt; 60°C TRAC12ATEX0040X</p>	<p>n/a</p>
 <p>GS007 Series Sensor</p>	 <p>GS820-10</p>	
<p>Notes:</p> <ol style="list-style-type: none"> <li>1) Operating temperature range -20°C &lt; Tamb &lt; +75°C</li> <li>2) Installation and maintenance must only be done by competent personnel</li> <li>3) Battery replacement shall only be accomplished if no explosive gas may be present</li> <li>4) Installation shall be in accordance with 60079.14 and other local regulations as may be required  </li> <li>5) Dissimilar metal contact should be avoided.</li> </ol>	<p>Notes:</p> <ol style="list-style-type: none"> <li>1) Operating temperature range -30°C &lt; Tamb &lt; +60°C</li> <li>2) See Installation Instruction GM820-10&amp;11_rev1_20120902</li> <li>3) Installation and maintenance must only be done by competent personnel</li> <li>4) GS820-xx must be returned to factory for service</li> <li>5) Installation shall be in accordance with 60079.14 and other local regulations as may be required  </li> <li>6) Dissimilar metal contact should be avoided.</li> </ol>	<p>Notes:</p> <ol style="list-style-type: none"> <li>1) Operating temperature range -30°C &lt; Tamb &lt; +60°C</li> <li>2) Installation and maintenance must only be done by competent personnel</li> <li>3) Installation shall be in accordance local regulations as may be required</li> <li>4) Dissimilar metal contact should be avoided.</li> </ol>

# EU Declaration of Conformity



**Manufacturer's Name:** Trimble Navigation, Ltd.

**Manufacturer's Address:** 2666 boul. du Parc Technologique, Suite 190  
Québec, QC, Canada, G1P 2J7

**Object of the declaration :**

MODEL No.	DESCRIPTION	MODEL VARIATIONS
GS007-xx-ATEX-yy	Load Pin Transmitter	xx (nil) = Standard Software version 01, 02, etc. = Alternate Software yy 10 = 903-927 MHz Transceiver 11 = 868-869 MHz Transceiver

**Product Marking:**

**II 1 G Ex ia IIC T4 Ga Tamb: -20°C to +75°C** **0891**

We, the manufacturer, declare under our sole responsibility that the products to which this declaration refers are in conformity with the essential requirements and other relevant requirements of the following European Directives:

2014/34/EU	ATEX Directive
------------	----------------

In accordance with the conformity assessment procedures described in Annex III and VII of the ATEX Directive, the listed products are covered by:

Sira 14ATEX2332X	EC Type Examination Certificate delivered by Sira Certification Service (NB 0518)
TRAC12QAN0007	Product Quality Assurance Notification delivered by Trac Global (NB 0891)

The following harmonized standards were applied:

EN 60079-0:2012/A11:2013	Explosive atmospheres. Equipment - General requirements
EN 60079-11:2012	Explosive atmospheres. Equipment protection by intrinsic safety 'i'
EN 60079-26:2007	Explosive atmospheres. Equipment with Equipment Protection Level (EPL) Ga

Québec, April 20th, 2016

\_\_\_\_\_  
Marc Chouinard, Eng.  
Ex Responsible

**Document Revision History**

---

**Revision History**

Rev	Description	Approved
1	Draft Release. Created from scheduled drawing UM007	M. Chouinard
2	Update to the declaration of conformity	M. Chouinard

This manual is in accordance with the scheduled drawing “UM007” revision 0.3.

Any changes to this document must be approved by the Hazardous Area Systems Manager